

# OPAL

ALUMINIUM WINDOWS AND DOORS

## **OPAL DEFINITIVE & DELUXE** INSTALLATION GUIDE

# CONTENTS.

INTRODUCTION	3
TOOLS REQUIRED	4
TYPICAL SECTION DETAILS	5
OPAL DEFINITIVE (1000 SERIES) - OPEN IN - REBATED OUTER FRAME (DV14)	5
OPAL DEFINITIVE (1000 SERIES) - OPEN IN - FLUSH OUTER FRAME (DV17)	6
OPAL DEFINITIVE (1000 SERIES) - OPEN OUT - FIXED TRACK INTEGRATED CILL (DV176)	7
OPAL DEFINITIVE (1000 SERIES) - OPEN OUT - REBATED OUTER (DV14)	8
OPAL DEFINITIVE (1000 SERIES) - OPEN OUT - FLUSH OUTER (DV17)	9
OPAL DEFINITIVE (1000 SERIES) - OPEN OUT - TRACK 20 LOW THRESHOLD (DV273)	10
OPAL DEFINITIVE (1000 SERIES) - OPEN OUT - TRACK 20 LOW THRESHOLD (DV273) NO CILL	11
OPAL DEFINITIVE (1000 SERIES) - OPEN OUT - TRACK 20 LOW THRESHOLD (DV273) RAMPS (DV174)	12
OPAL DEFINITIVE (1000 SERIES) - OPEN OUT - TRACK 30 LOW THRESHOLD (DV175)	13
OPAL DEFINITIVE (1000 SERIES) - OPEN OUT - TRACK 30 LOW THRESHOLD (DV175)	14
OPAL DELUXE (6000 SERIES) - OPEN IN - REBATED OUTER (DV610)	15
OPAL DELUXE (6000 SERIES) - OPEN IN - FLUSH OUTER (DV612)	16
OPAL DELUXE (6000 SERIES) - OPEN IN - FRAME EXTENDERS	17
OPAL DELUXE (6000 SERIES) - OPEN OUT - REBATED OUTER (DV610)	18
OPAL DELUXE (6000 SERIES) - OPEN OUT - FLUSH OUTER (DV612)	19
OPAL DEFINITIVE & DELUXE SERIES	20
BRICK OPENING TOLERANCES	20
INSTALLING THE CILL & OUTER FRAME	21
INSTALLING THE CILL & OUTER FRAME	22
INSTALLING THE CILL & OUTER FRAME	23
DOOR SASH INSTALLATION	24
DOOR SASH INSTALLATION	25
GLAZING. TOE & HEELING	26
TOE & HEELING (GLASS ADJUSTER KIT)	27
TOE & HEELING (GLASS ADJUSTER KIT)	28
TOE & HEELING	29
TOE & HEELING	30
TOE & HEELING CONTINUED	31
TRAFFIC DOOR MAGNET RETAINER	32
DOOR RESTRICTOR (ACDV290)	33

# INTRODUCTION

This guide provides an overview of the installation of the Prefix OPAL Definitive and OPAL Deluxe Bi-fold doors (Visofold 1000 & 6000). Any areas or details not covered in this guide can be discussed with our technical support team via our WhatsApp: 07384 836437.

This guide is written on the basis that an accurate site survey has been undertaken. Please take a moment to read through and understand this guide prior to assembly. All feedback is welcome.

## IMPORTANT: PLEASE READ BEFORE COMMENCING INSTALLATION

- Ensure the correct tolerances have been allowed during survey. Check that the opening is structurally supported, square, plumb and level before you start - this will enable you to see where additional packing may be required before you position the door. Any damaged DPM should be repaired/ replaced and any open cavities bridged or closed.
- Please take care when handling painted product as surfaces may become scratched. Check ALL profiles and product for any damage prior commencing installation. Any damage must be reported before installation takes place.
- Safety precautions should be observed at all times.
- The Definitive and Deluxe systems described in this manual are suitable for domestic and commercial applications and provide various opening options using slim-line sections.
- The frames are constructed from aluminium alloy extrusion to BS EN 755, extruded from 6063 T6 Alloy. The external aluminium alloy extrusion is pre-treated and finished in polyester powder organic coating to BS 6496.
- As with all dry glazed systems, it is recommended that the system is drained and ventilated in line with the details shown in this manual.
- OPAL Definitive and Deluxe offer multi-point locking for the primary leaf, locked by lifting the handle and turning the key of the euro profile cylinder.
- Secondary doors are closed using either:
  - A shoot bolt, which engages into the head and threshold using a rotating handle. There is no external access to the shoot bolt locking.
  - A lever/ lever operated lock which engages into the head and threshold. This option offers external access.
- **Important: Shoot bolt handles are not designed to open and close the doors. ACDV234/ACDV274 D handles must be used. Remove any keys from shootbolt cylinders prior operating doors to prevent damaging stiles when folding doors.**

## TOOLS REQUIRED.



Battery/Drill Driver

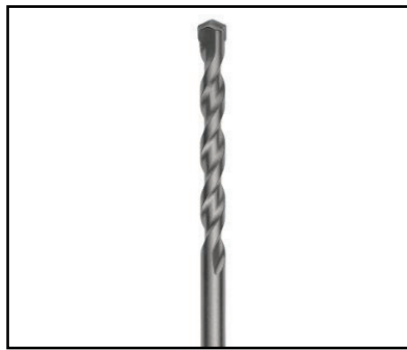

Suitable masonry bits



Driver bits (typically PZ, PH, TX)

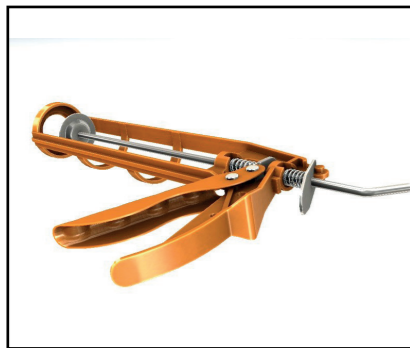

Silicone Gun



Nylon Mallet



Tape Measure



Glazing Shovel



Glazing Packers



Spirit Level



Angle Finder



Gasket Roller

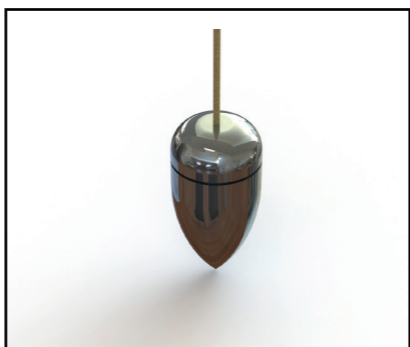

Plumb Line

## TYPICAL SECTION DETAILS

OPAL Definitive (1000 Series) - Open In - Rebated Outer Frame (DV14)

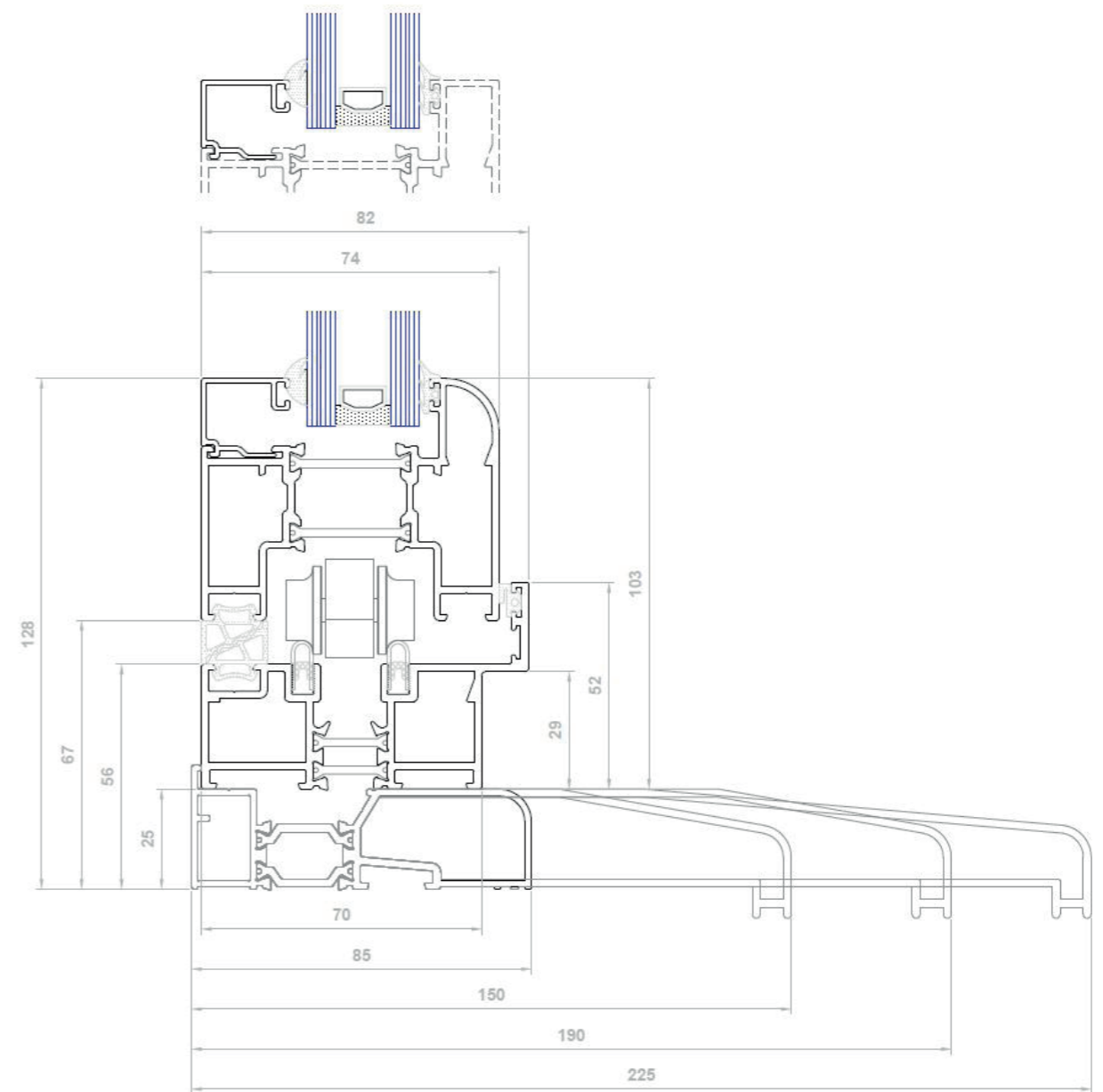

**DO NOT SCALE FROM DRAWING**

# TYPICAL SECTION DETAILS

OPAL Definitive (1000 Series) - Open In - Flush Outer Frame (DV17)

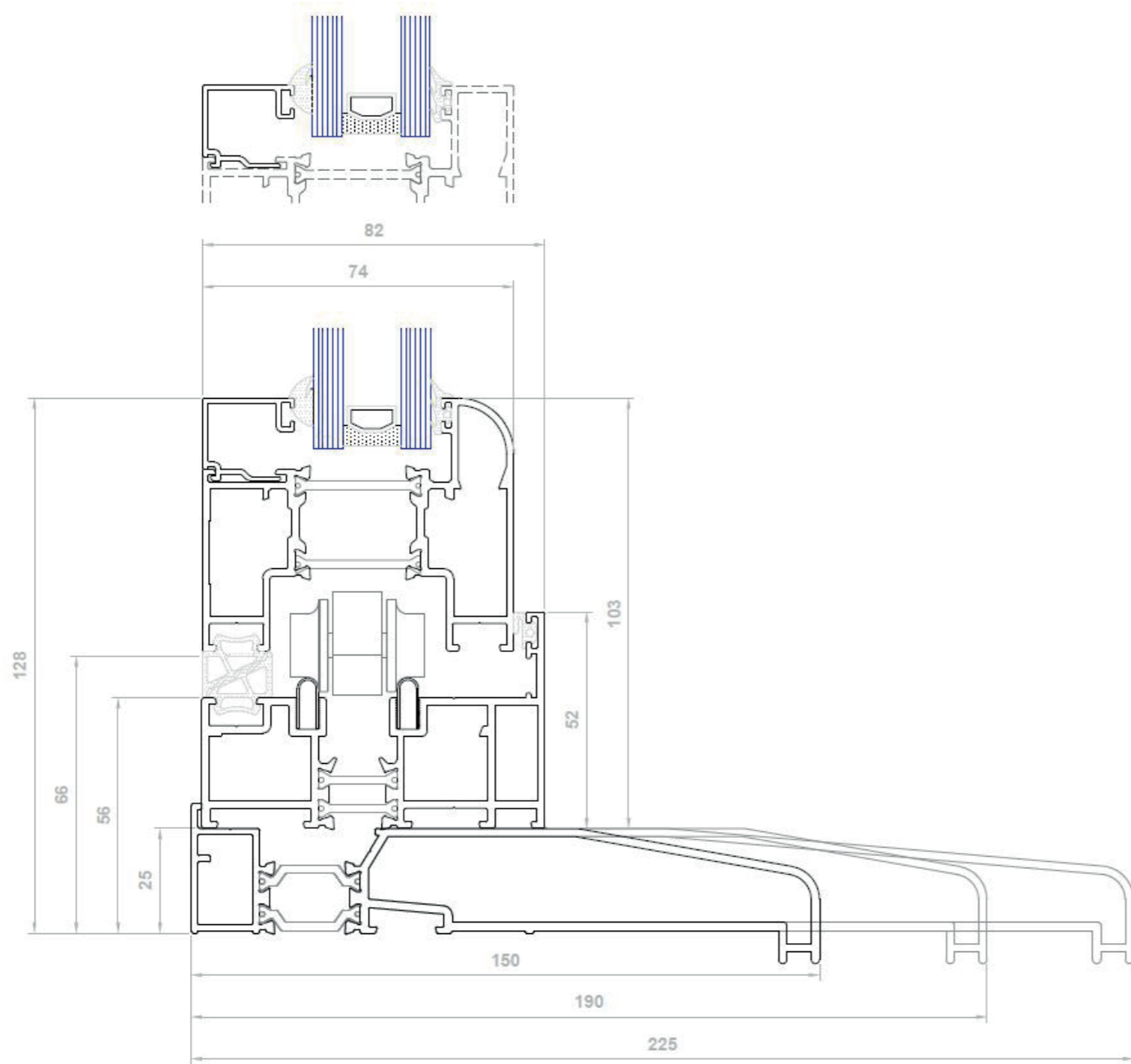

**DO NOT SCALE FROM DRAWING**

# TYPICAL SECTION DETAILS

OPAL Definitive (1000 Series) - Open Out - Fixed Track Integrated Cill (DV176)

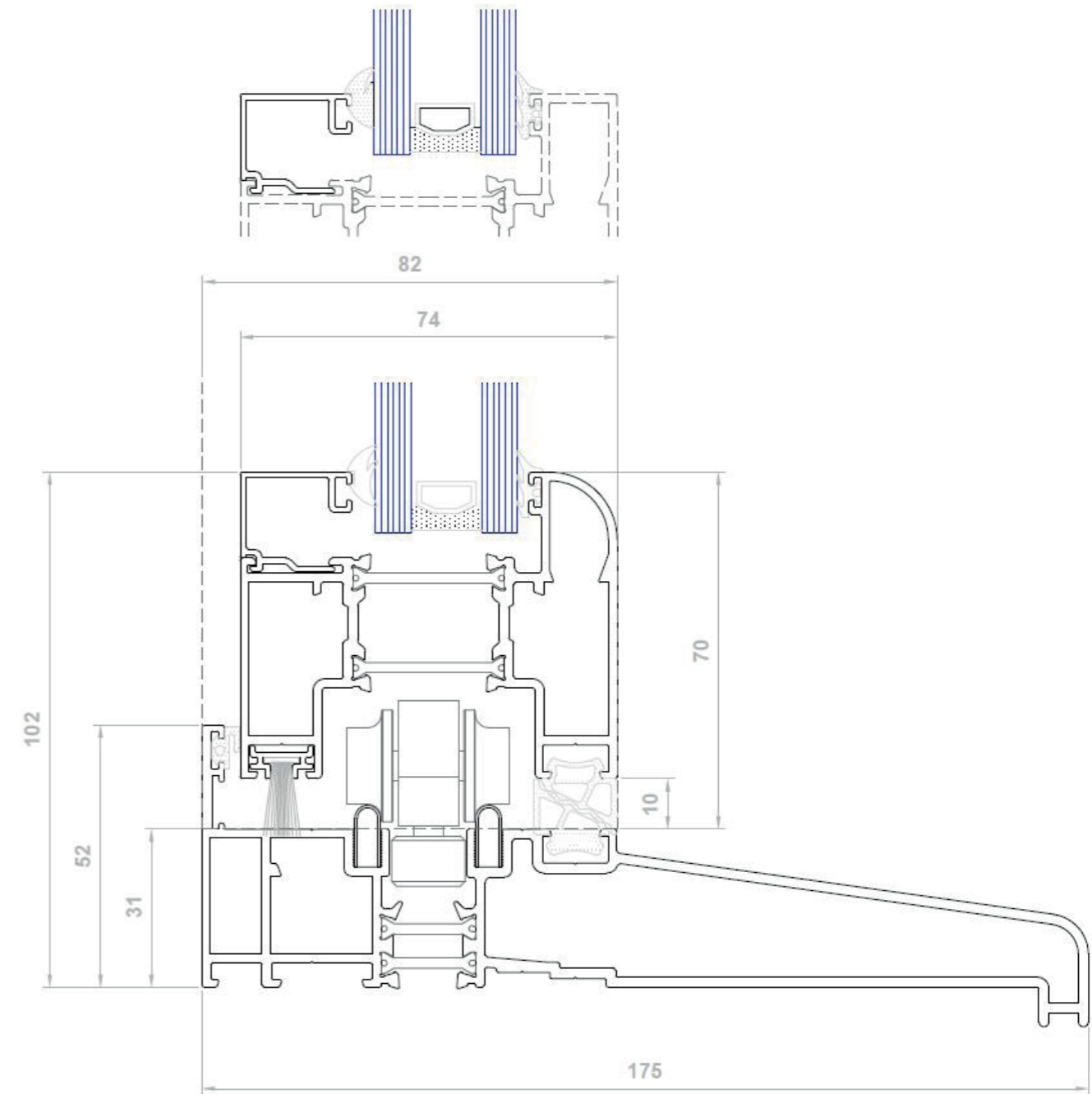

**DO NOT SCALE FROM DRAWING**

# TYPICAL SECTION DETAILS

OPAL Definitive (1000 Series) - Open Out - Rebated Outer (DV14)

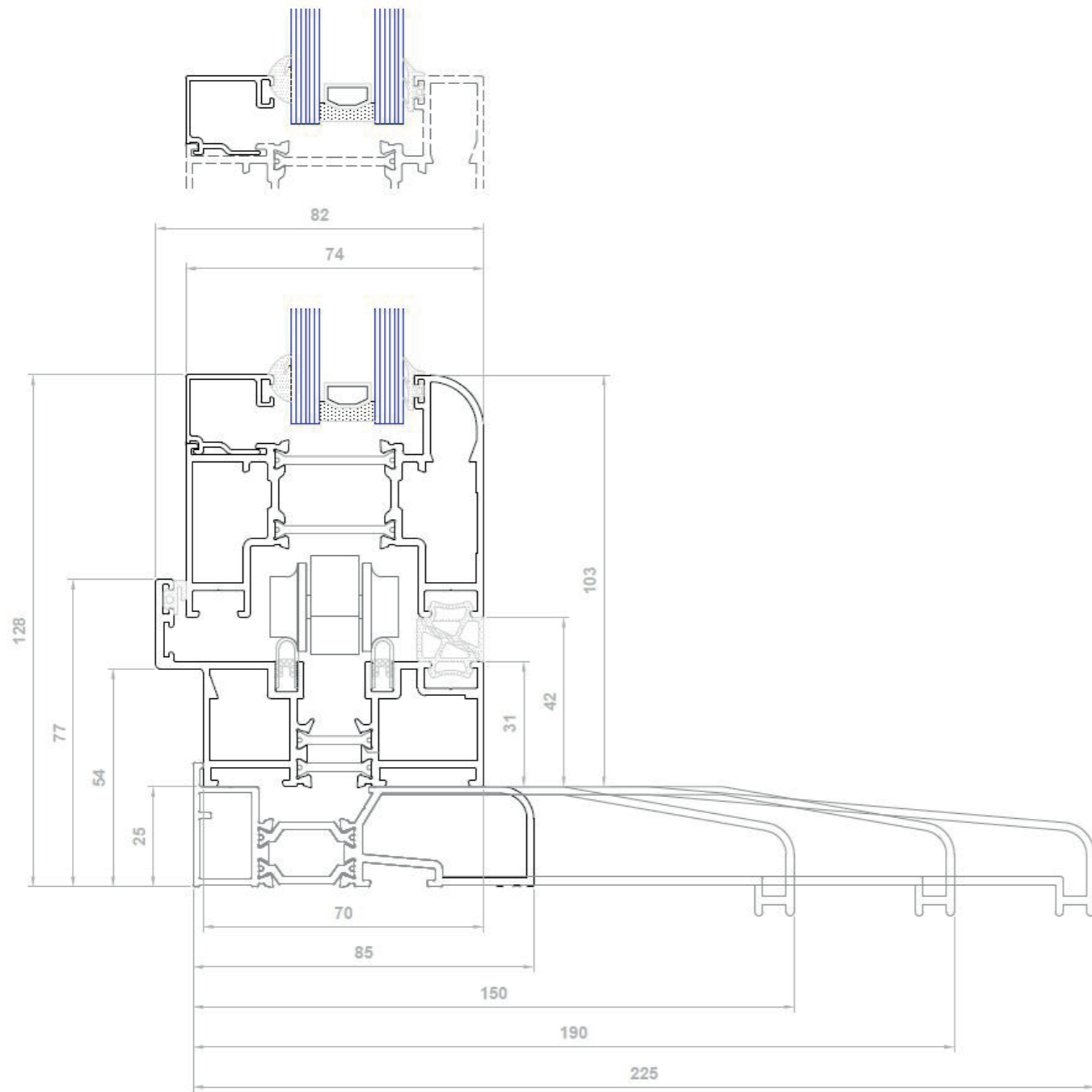

DO NOT SCALE FROM DRAWING

# TYPICAL SECTION DETAILS

OPAL Definitive (1000 Series) - Open Out - Flush Outer (DV17)

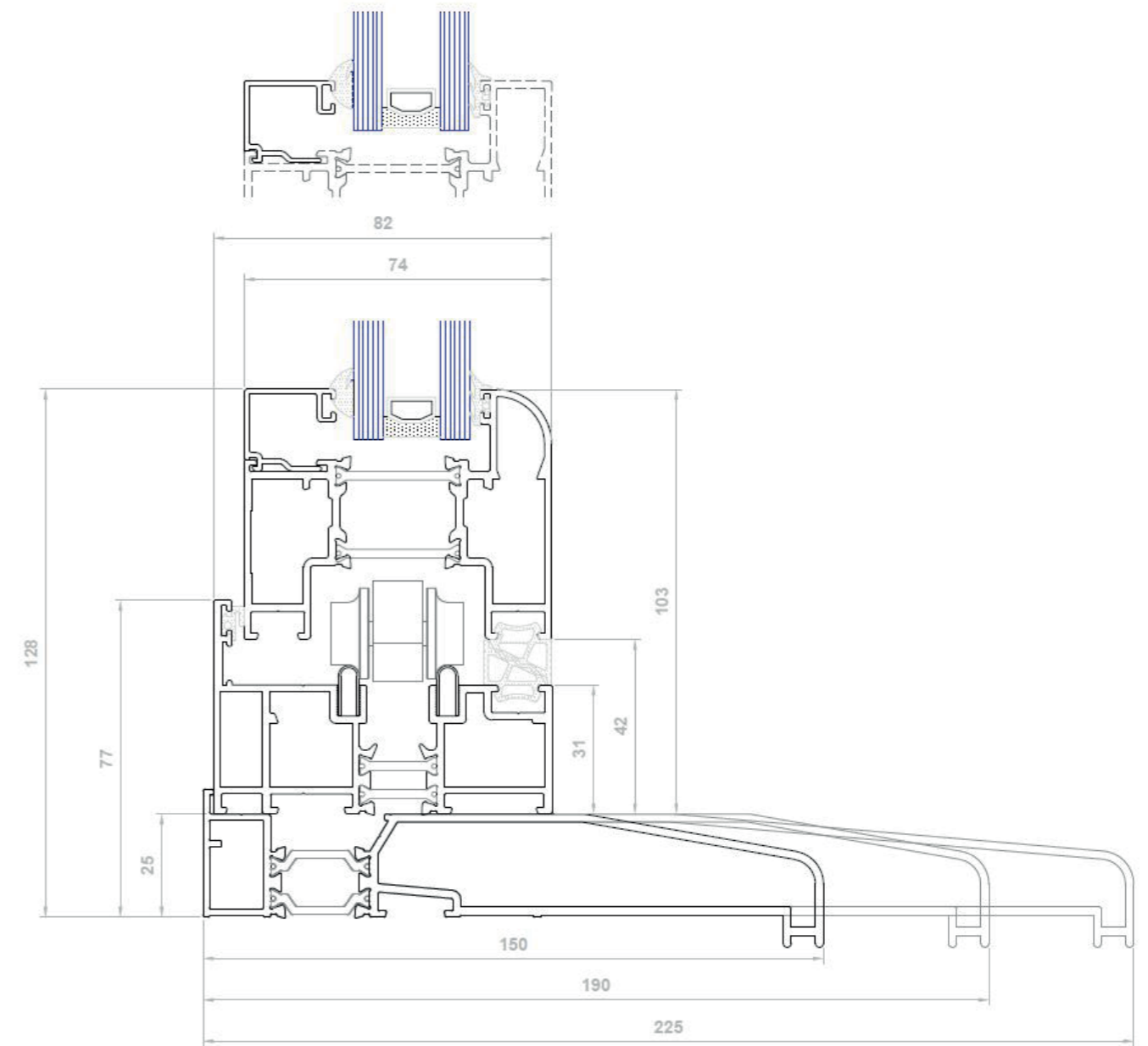

DO NOT SCALE FROM DRAWING

## TYPICAL SECTION DETAILS

OPAL Definitive (1000 Series) - Open Out - Track 20 Low Threshold (DV273)  
Open Out Only

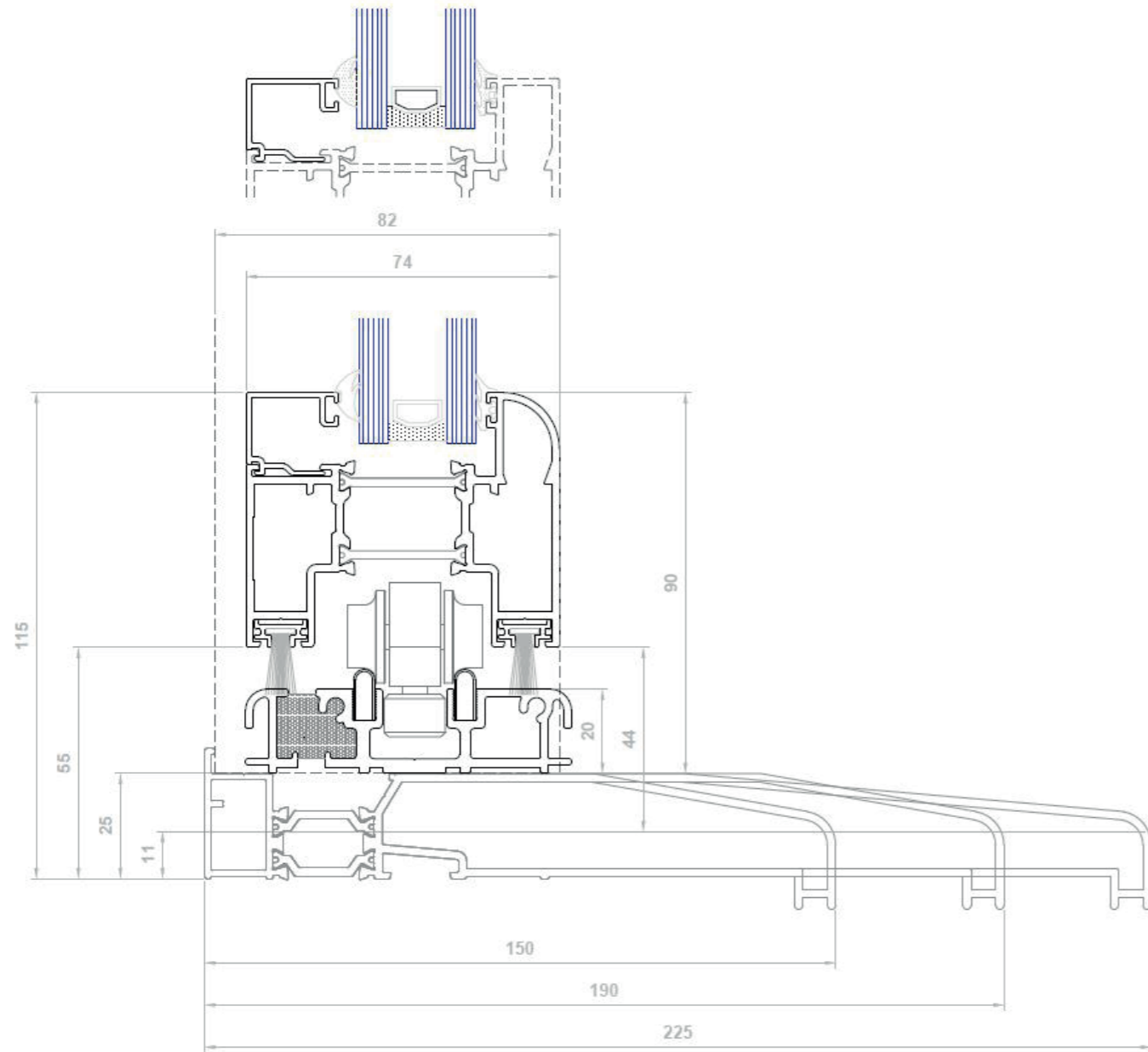

DO NOT SCALE FROM DRAWING

## TYPICAL SECTION DETAILS

OPAL Definitive (1000 Series) - Open Out - Track 20 Low Threshold (DV273)  
(DV273) No Cill

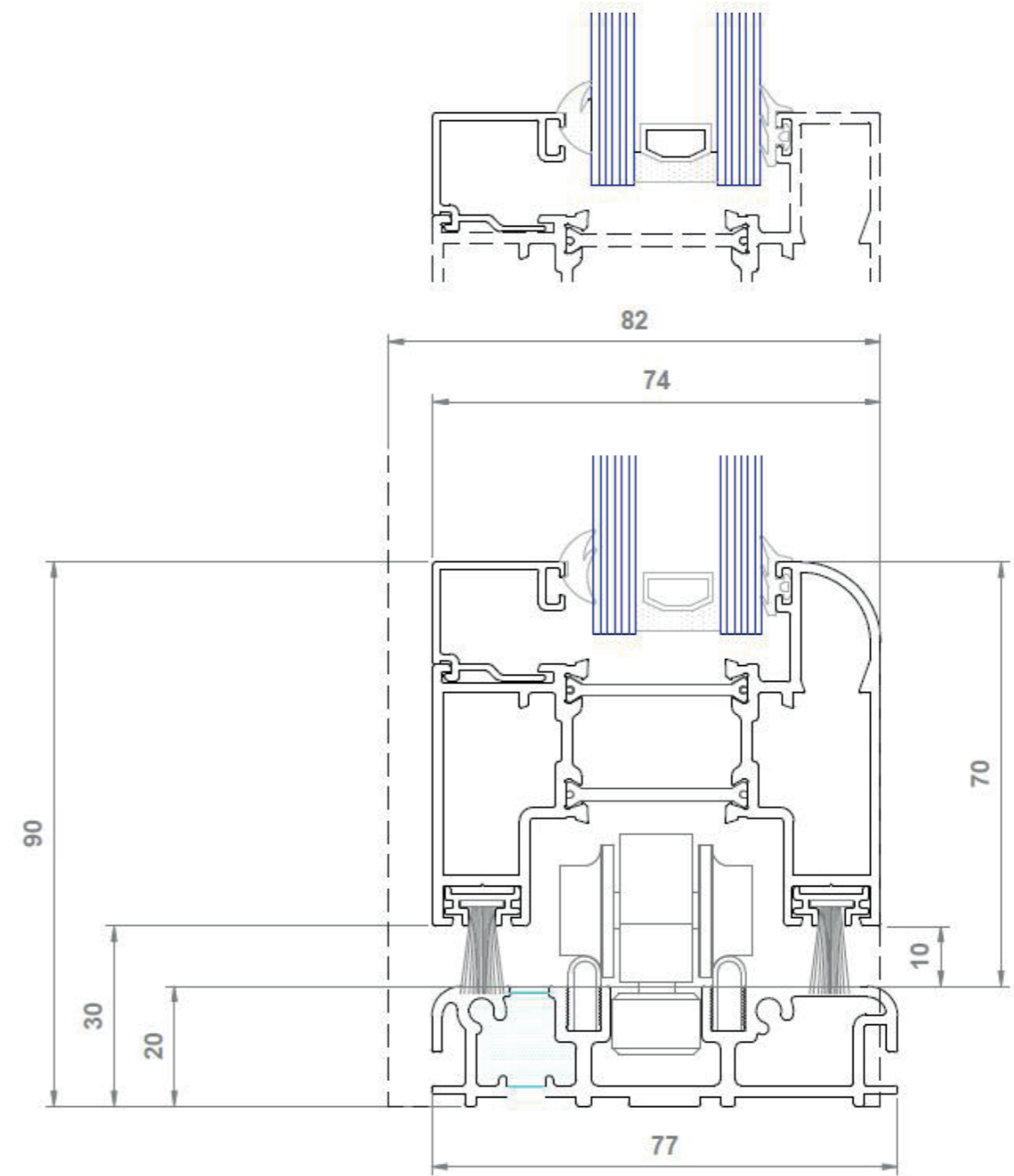

DO NOT SCALE FROM DRAWING

## TYPICAL SECTION DETAILS

OPAL Definitive (1000 Series) - Open Out - Track 20 Low Threshold (DV273) Ramps (DV174)

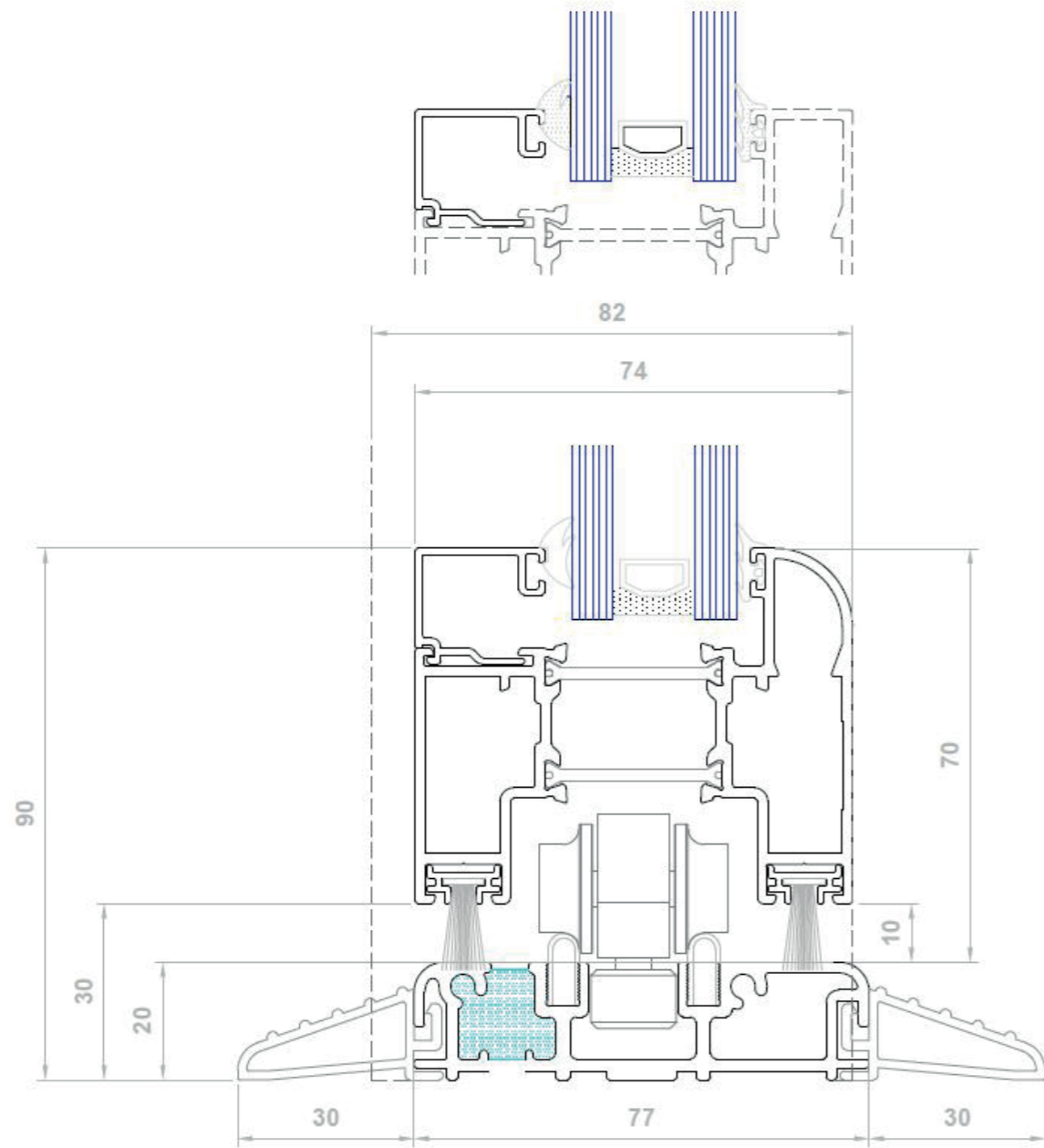

**DO NOT SCALE FROM DRAWING**

## TYPICAL SECTION DETAILS

OPAL Definitive (1000 Series) - Open Out - Track 30 Low Threshold (DV175)

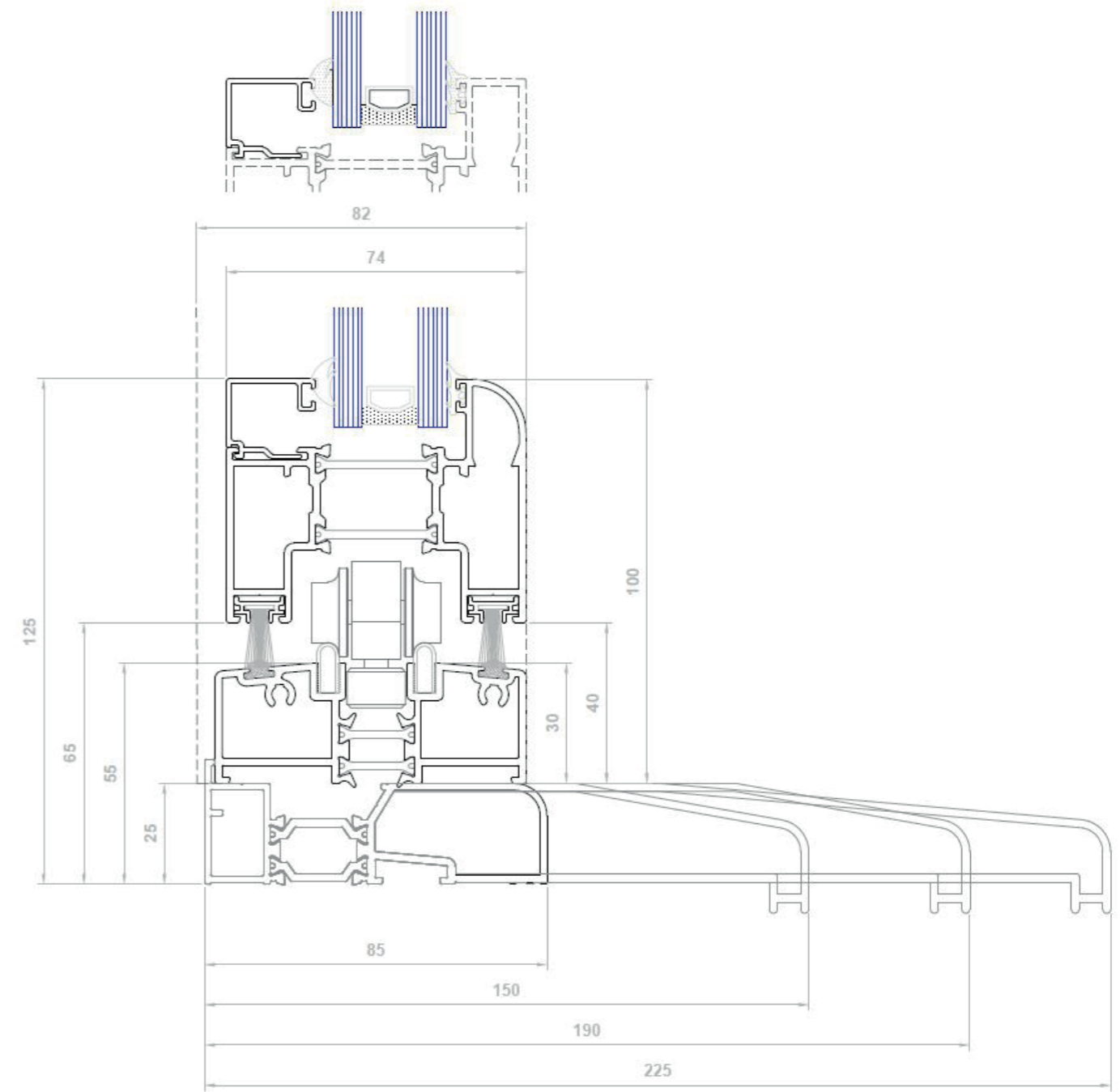

**DO NOT SCALE FROM DRAWING**

## TYPICAL SECTION DETAILS

OPAL Definitive (1000 Series) - Open Out - Track 30 Low Threshold (DV175)

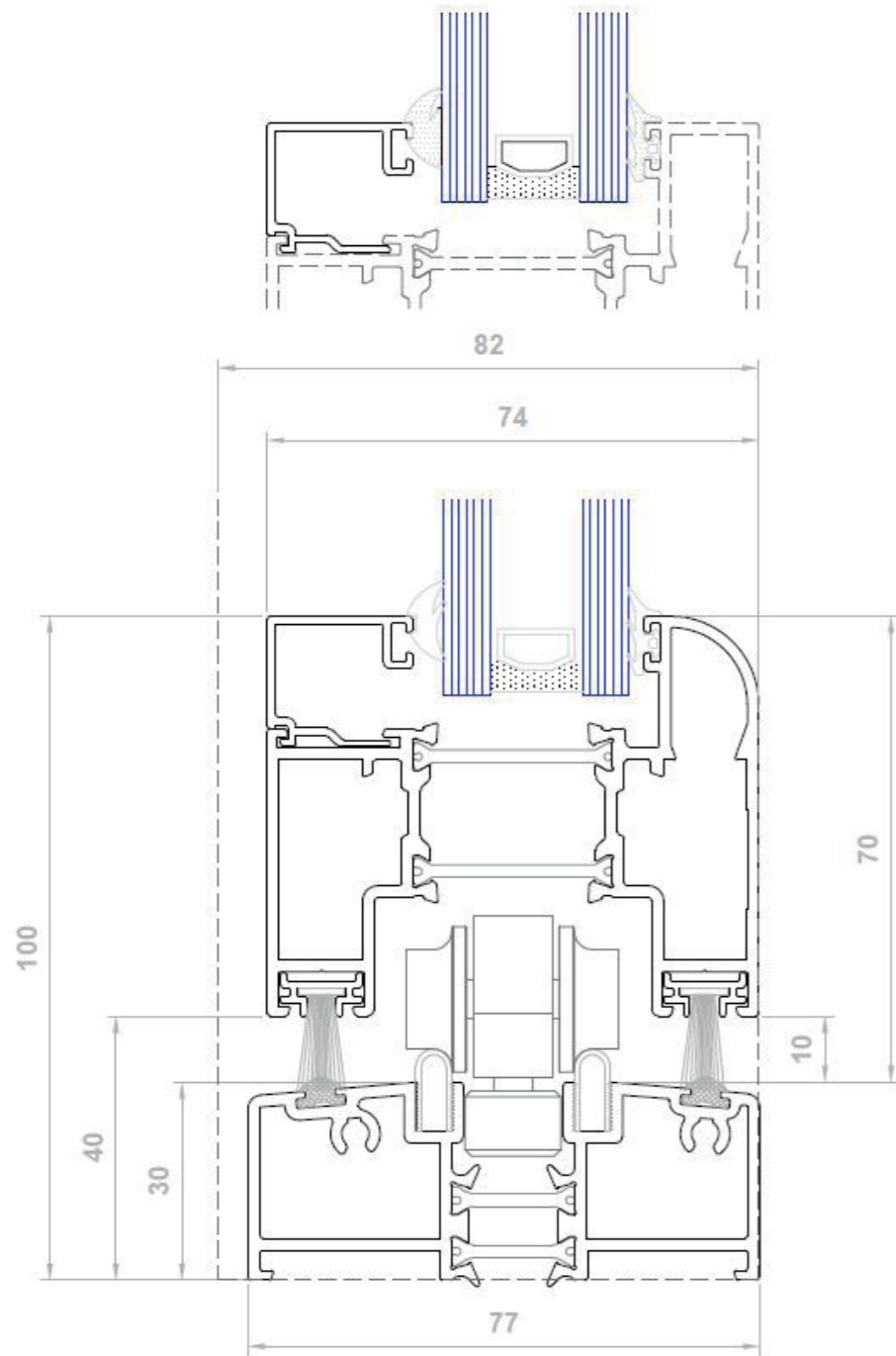

DO NOT SCALE FROM DRAWING

## TYPICAL SECTION DETAILS

OPAL Deluxe (6000 Series) - Open In - Rebated Outer (DV610)

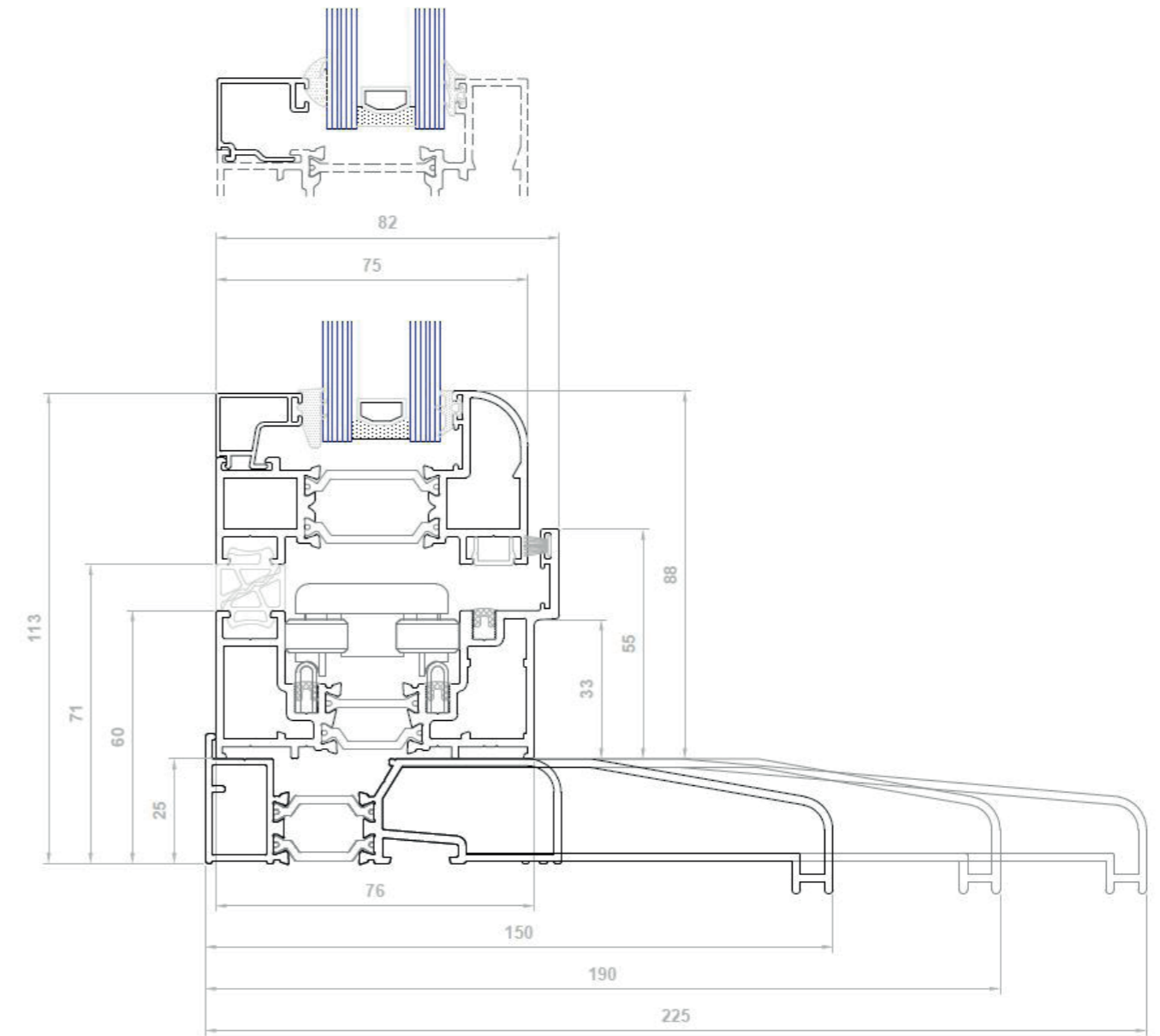

DO NOT SCALE FROM DRAWING



# TYPICAL SECTION DETAILS

OPAL Deluxe (6000 Series) - Open In - Flush Outer (DV612)

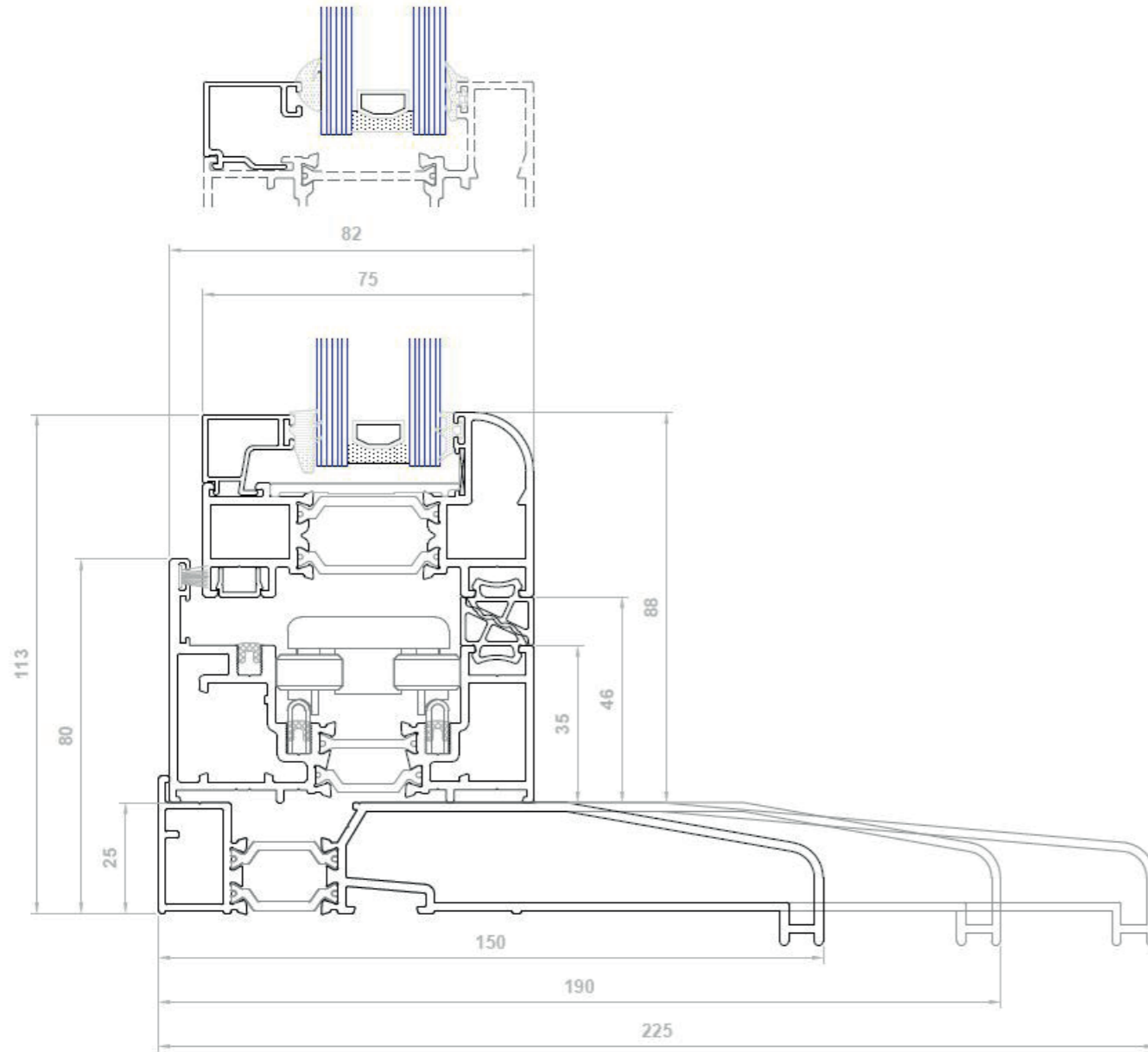

DO NOT SCALE FROM DRAWING

# TYPICAL SECTION DETAILS

OPAL Deluxe (6000 Series) - Open In - Frame Extenders

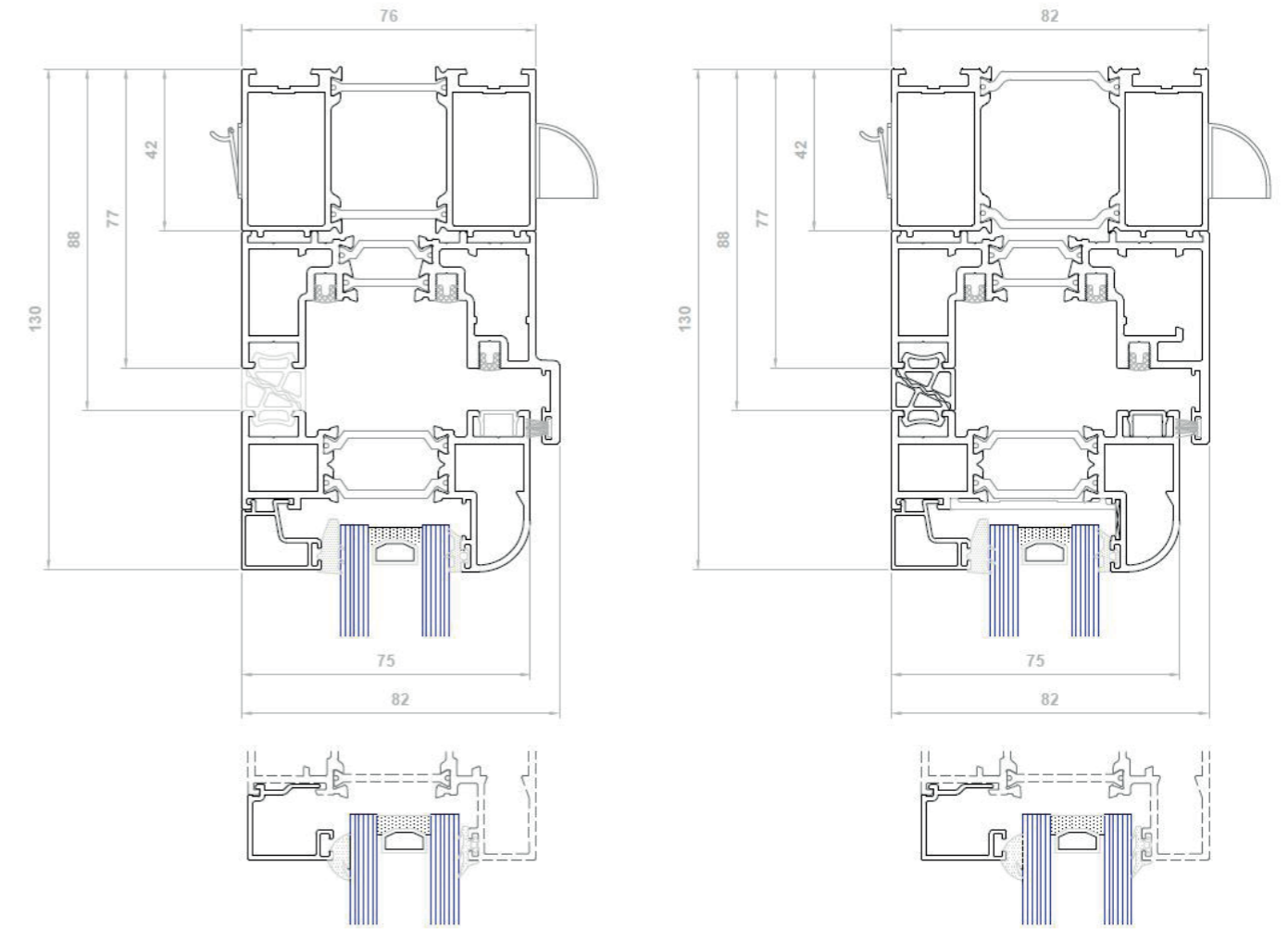

DO NOT SCALE FROM DRAWING

## TYPICAL SECTION DETAILS

OPAL Deluxe (6000 Series) - Open Out - Rebated Outer (DV610)

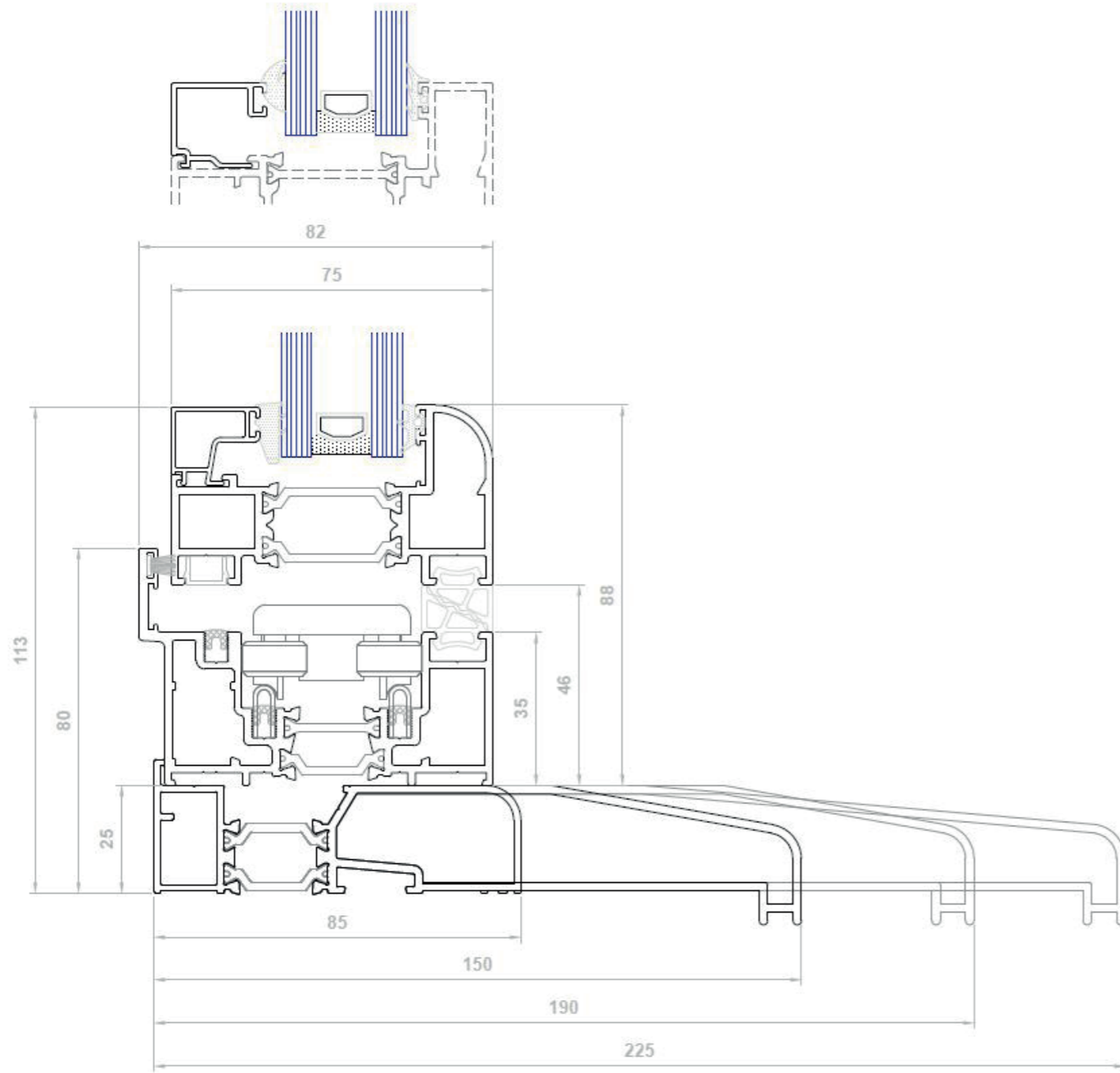

DO NOT SCALE FROM DRAWING

## TYPICAL SECTION DETAILS

OPAL Deluxe (6000 Series) - Open Out - Flush Outer (DV612)

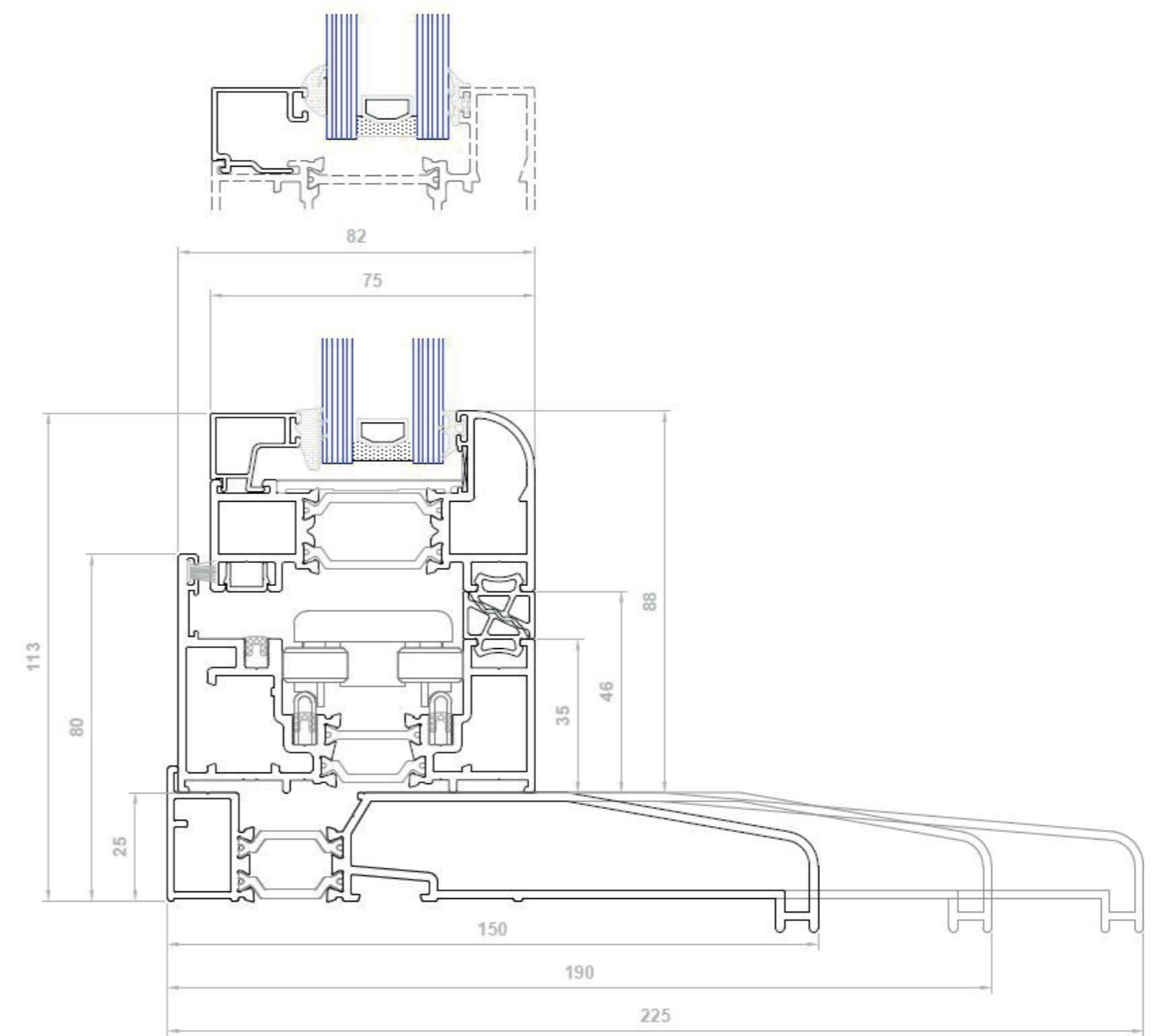

DO NOT SCALE FROM DRAWING

## OPAL DEFINITIVE & DELUXE SERIES



### BRICK OPENING TOLERANCES

- >1.5m allow 5mm per side
- 1.5m - 3.0m allow 5mm per side
- 3.0m - 4.5m allow 7.5mm per side
- 4.5m < allow 10mm per side

## INSTALLING THE CILL & OUTER FRAME

Please note: Where bi-folds have 4 or more panes, the outer frame may be separated from the sashes. The opening must be structurally sound, with the brick/substrate above supported with an approved structural element. Check outer frame will fit the opening with 10-15mm clearance (see recommended clearance tolerance table page 20). Outer frame is measured from underside of cill, not Finished Floor Level.



**Important Note:** Due to the integrated drainage, cills must have the ability to drain. Avoid honing of the cills as a safeguard against water egress.

Prior installation, cill end caps and any joints must be fitted using ASCILO4 sealant. Dam the internal cavity of the cill using suitable backing rod (supplied by others) and apply generous amount of sealant before pushing the end caps into position.



Once cill end cap is fitted, dam this area with ASCILO4 to prevent any water egress.

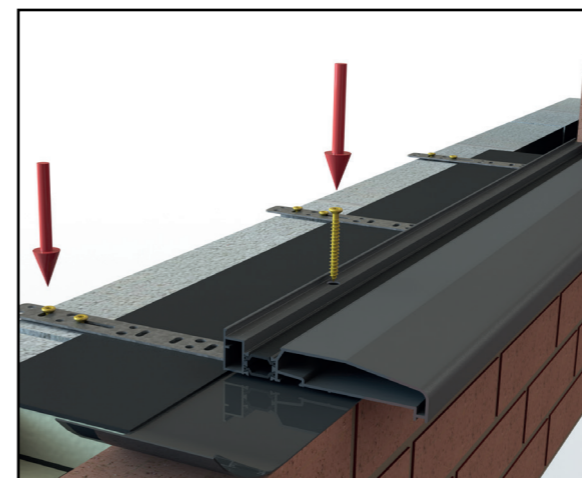

Cill must be fitted into the opening before the outer frame. Ensure area is free from debris and old silicone and make sure there is no damage to the DPC.

**It is critical that cill is installed level, using precision measuring equipment, gauge and pack as necessary before fixing.**

If securing directly into substrate, fixing must be through the rear aluminium profile (not through the thermal breaks), using suitable fixings (supplied by others). Alternatively, fixing straps can be used to fix to inner blockwork. Fixings to be 150mm from each end, and max. 600mm centres.

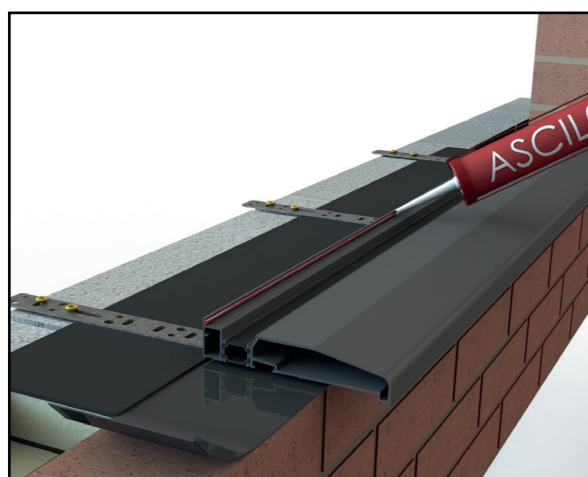

If applicable, fit any frame add-ons prior to this stage. Run continuous bead of ASCILO4 sealant along the back edge of the cill to bond the outer frame to the cill. Base of frame **MUST NOT** be mechanically fixed into cill.

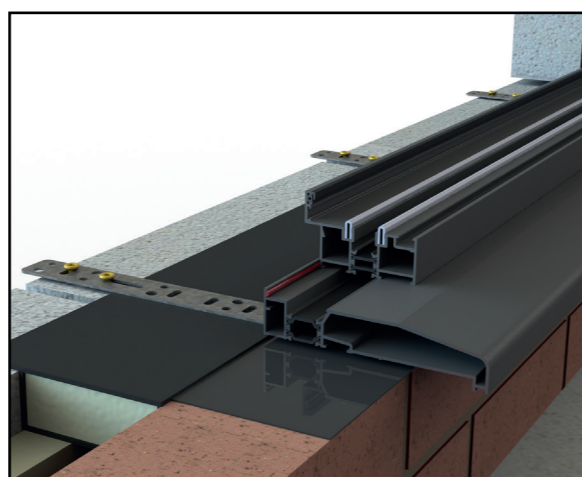

Carefully lift frames into the aperture, being careful not to catch frames on substrate. If using fixing straps these will need locking to the outer frame before lifting into position.



Locate packers on or close to fixing positions where possible. Using suitable fixings for the substrate 150mm (min 100mm), mechanically fix frames into position 150mm away from each corner and at max. 600mm centres thereafter.

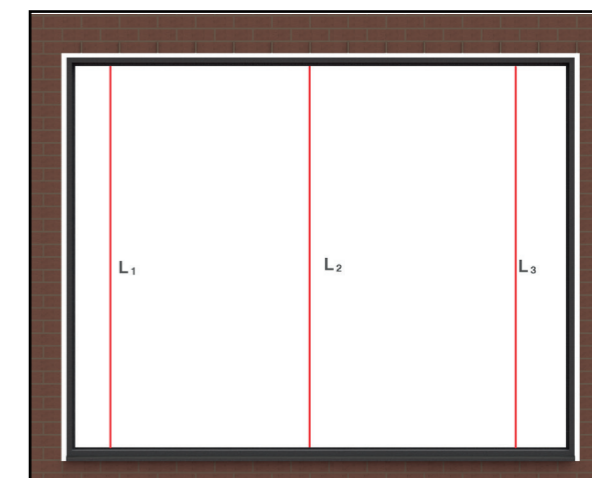

Take regular measurements along the span and heights of the frame. Double check for any bowing and/or twisting in the frames and adjust accordingly. It is critical that the out frame is level and square for the doors to work.

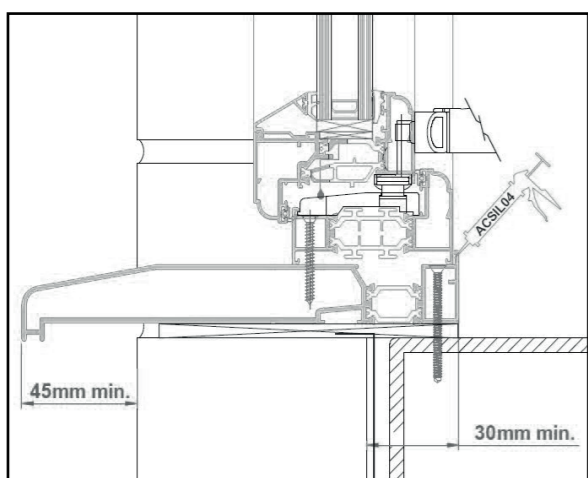

If direct fixing outer frame to cill is required, ensure this is done through front section of aluminium to prevent water egress in the wrong areas. Screw must not protrude through underside of cill profile. (40mm Max. Length). Follow packing steps before any mechanical fixing of frames takes place.

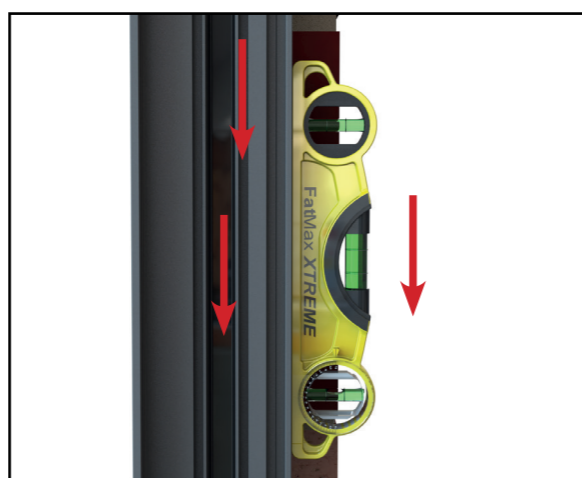

Ensure frame is plumb, square and level before fixing, with no unevenness, bowing or twisting. Pack frame at regular intervals starting on the sides before the head of the frame. Take care not to cause any bows or bends around the perimeter by over or under packing.

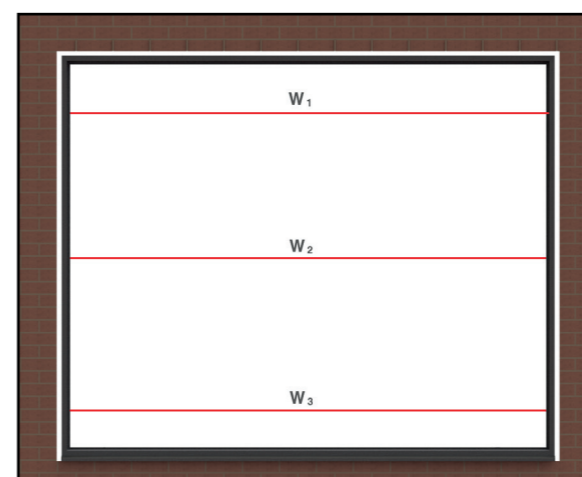

After fixing the frame work refrain from sealing and trimming up the outer frame to brickwork until doors are fully glazed and operational to allow adjustment should the need arise at a later stage.

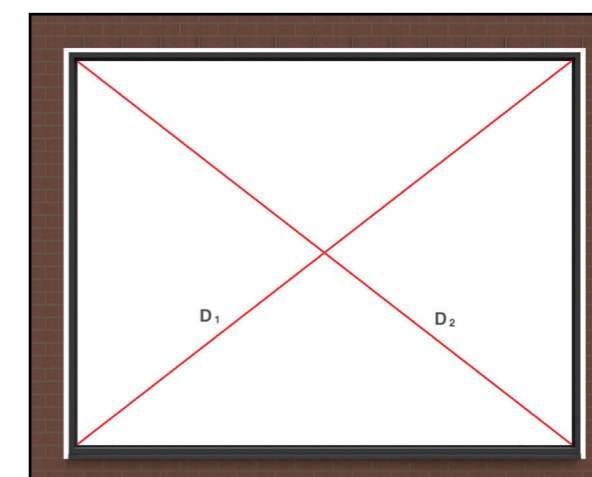

**Load bearing capability must not be transferred to any part of the frame when fitted. Taking care at this point will save time with the rest of the install.**

## DOOR SASH INSTALLATION.



Where possible, Bi-Folds up to 3 Pane are sent out fully assembled. On large openings (4, 5, 6 Pane etc.) 2 panes will be factory fitted in the outer frame. Sash numbers for loose panes can be found at the bottom of each vertical door stile to identify installation order of each door sash.



Hardware will already be assembled to 1 door sash. In sequence, lift the next door into position and line up hinge plate, ensuring door is level with a constant 11mm gap between sash and frames. Fix the top and bottom hole only at this point using the 'First Fix' Ø4 x8mm CSK machine screws provided.

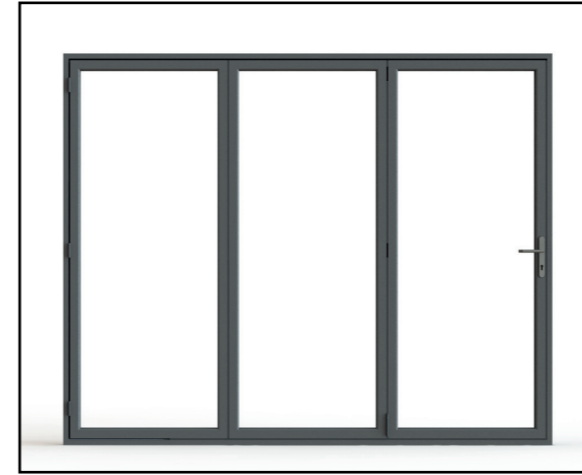

Ensure all door leaves are aligned and level with a constant 11mm gap around perimeter of doors (Gasket Width).

**Sliding mullions will be pre-fitted to relevant door sash in factory with appropriate gearing and hardware. Install as previous steps.**

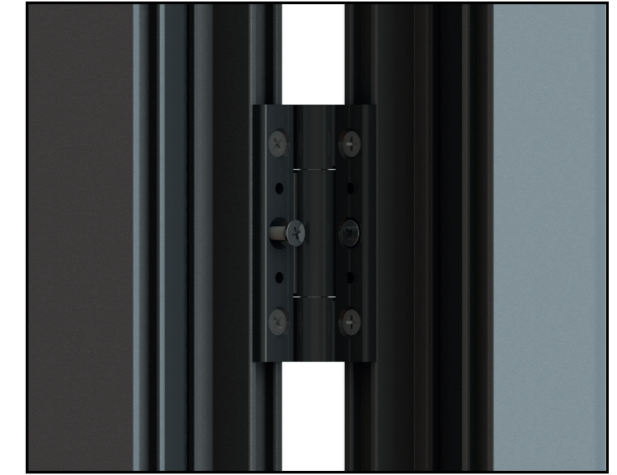

After all doors have been fitted, glazed and the following toe and heeling operations have been completed, double check alignment and fix the 'final fix screw' through the remaining central hole in each hinge using the Ø4.8 x 25mm CSK Stainless Steel Self Drilling Screws provided (PZ2).

**Failing to install these screws will result in Bi-Fold Doors eventually failing.**

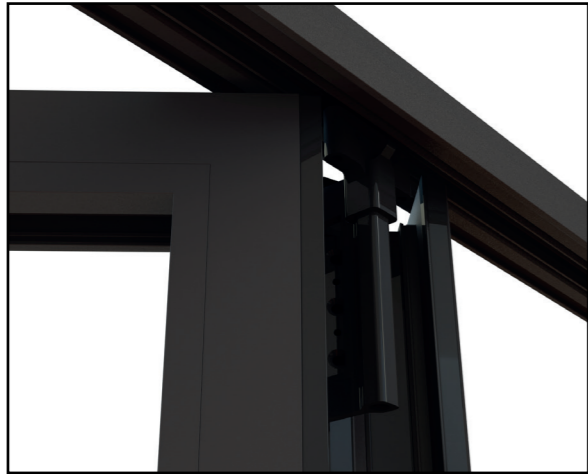

Guide rollers will already be assembled to the relevant door sash as part of the top hinge assembly. On an angle, lift door sash into position to allow guide roller to sit into rebated channel in the outer frame header.

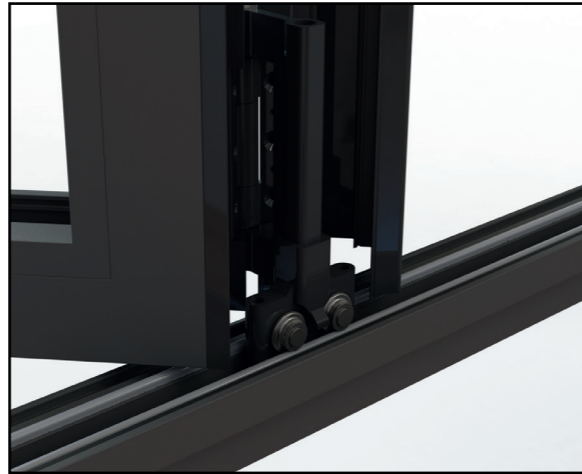

Bogey Hinge will already be assembled to the relevant door sash as part of the bottom hinge assembly. Once top is located into the channel, ensure the bottom guide rollers sit in the channel of the outer frame with the wheels on the tracks. Ensuring door is level with a constant 11mm gap between sash and frames. Fix the top and bottom holes of the hinge using the 'First Fix' Ø4 x8mm CSK screws provided.

## GLAZING, TOE & HEELING.



Remove the pre-glazed beading (4 per sash) making note of bead location.



Fit bottom glazing packers only prior to glass being installed. Lift glass units into door sash (2 people required). Once positioned follow toe and heeling guide on page 26 onwards before re-installing beads.

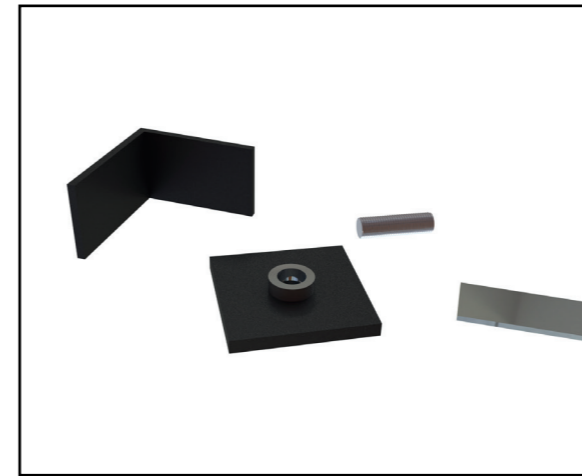

When door sashes measure 950mm + wide, glass adjustment kits are supplied as an aid for toe & heeling. This kit comprises of a pre-fitted fixed plate and adjuster bolt along with a reinforcing plate and L packer (supplied in box).

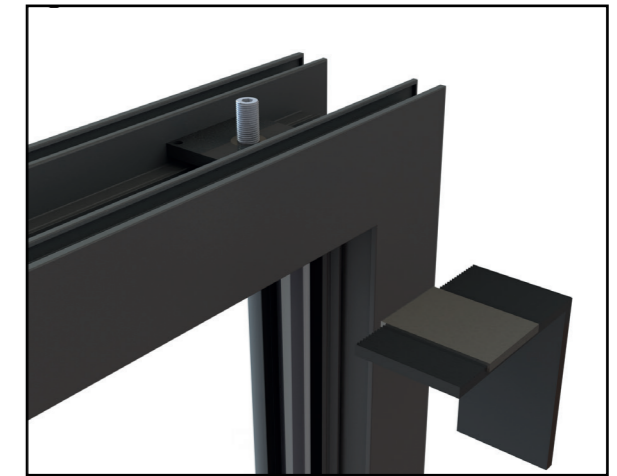

Locate the 'L Packer from the box. Position the reinforcing plate where the pre-fitted adjustment bolt will come into contact with the packer through the frame.

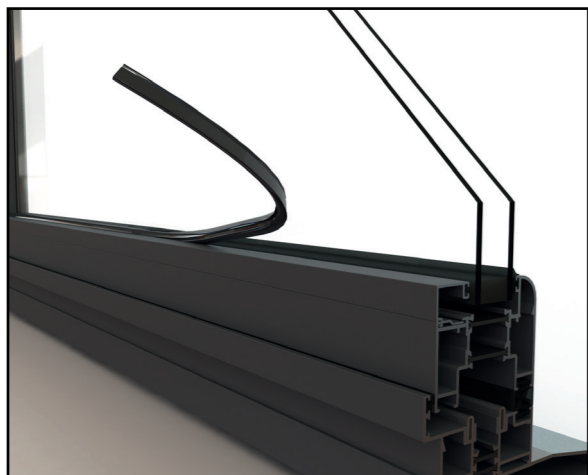

Once completed toe and heeling process, re-install glazing beads ensuring each bead goes back into its original location. Using the wedge gasket supplied, push fit between the bead and the glass on all 4 sides as 1 continuous length.



Cut V Notches to fit gaskets in the corners. For ease of installation use light solution of soapy water and glazing roller. When cutting gasket cut 5% longer to allow for any shrinkage. Do not stretch gasket when installing.



With the doors open slightly, push L Packer onto the corner of the glass unit in the top corner on the handle side of the sash.



Using a 4mm Allen Key, screw down the adjuster bolt ensuring contact with the reinforcing plate to required position.

## TOE & HEELING. (GLASS ADJUSTER KIT)

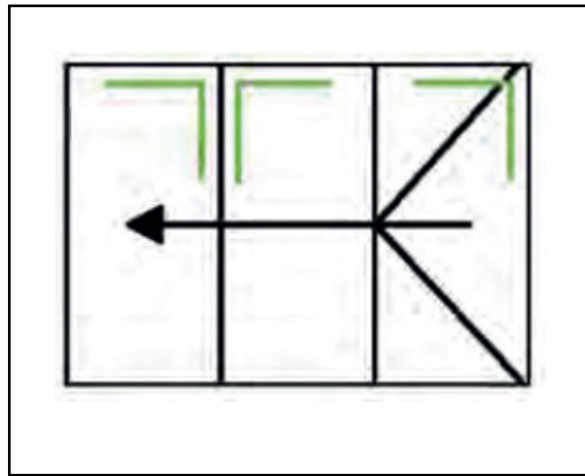

Example of glass adjuster kit position. This will be pre-fitted to the top of the door sash where toe and heel packers would usually be used. Bottom corners will be packed as shown in this guide leaving enough clearance for adjustment.

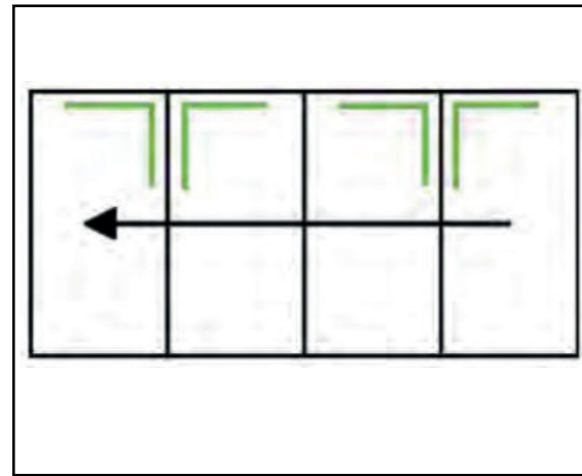

**WARNING: Incorrect operation will result in damage to the glass unit. The adjuster bolt must come into contact with the reinforcing plate and the glass must have sufficient clearance when adjustment is made. Glass must not touch sash at any point. If close, restart the process and re-adjust.**

## TOE & HEELING.

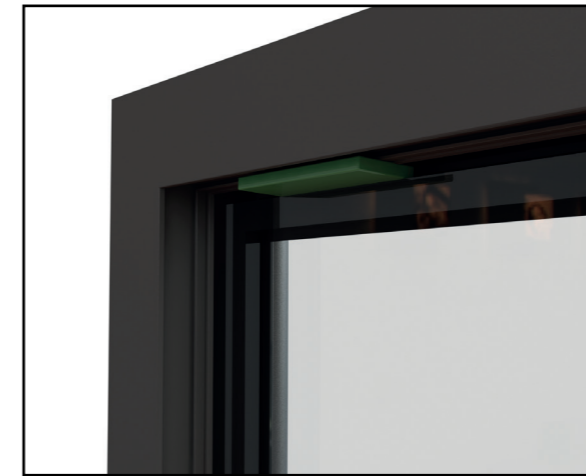

After glass unit is positioned on bottom packers, pack the top of the unit on the handle side until the glaze unit is secure in position.



Pack the top side of the unit on the handle side using a variety of packers until the glazed unit sits firmly in position and square in the frame.

**Caution Overpacking may cause sash to be pushed out of square.**



On the bottom edge of the door sash pack the side of the unit on the hinge side using a variety of packers until the glazed unit sits firmly in position and square in the frame.

**Caution Overpacking may cause sash to be pushed out of square**



Finally pack the top side corner on the hinge side of the door using a variety of packers until the glazed unit sits firmly in position and square in the frame. Silicone the upright packers to prevent them moving.

**Caution Overpacking may cause sash to be pushed out of square.**

# TOE & HEELING.

ALL CONFIGURATIONS VIEW FROM THE OUTSIDE

Toe & Heel	
	This symbol indicates where to pack each panel.
	Final Fix Packer

1 PANEL

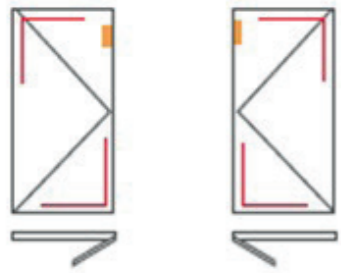

2 PANELS

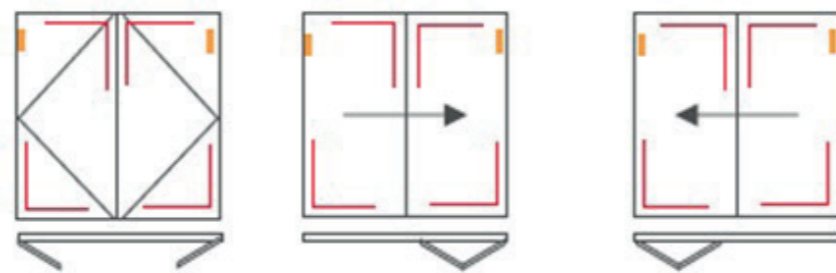

3 PANELS

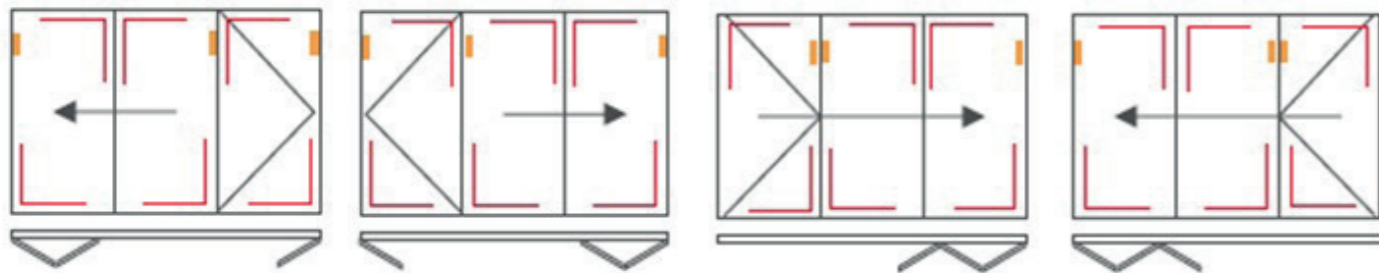

4 PANELS

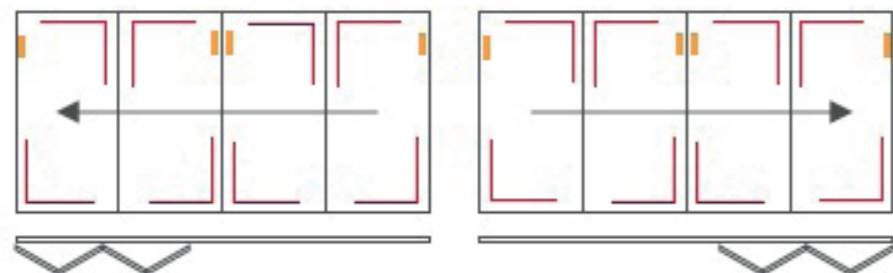
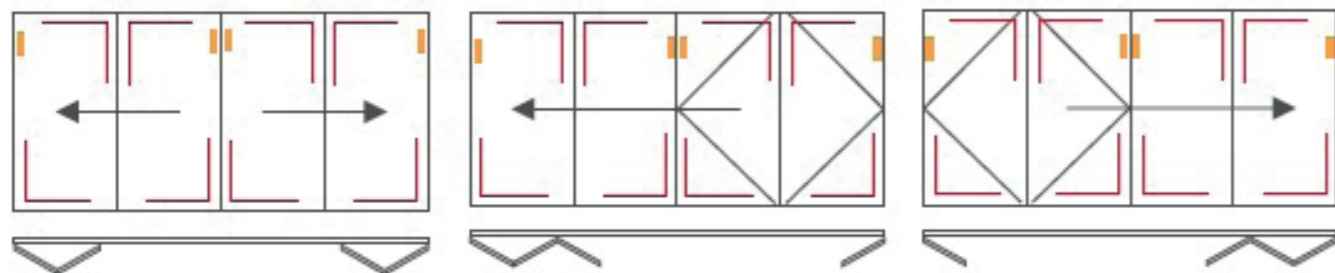

5 PANELS

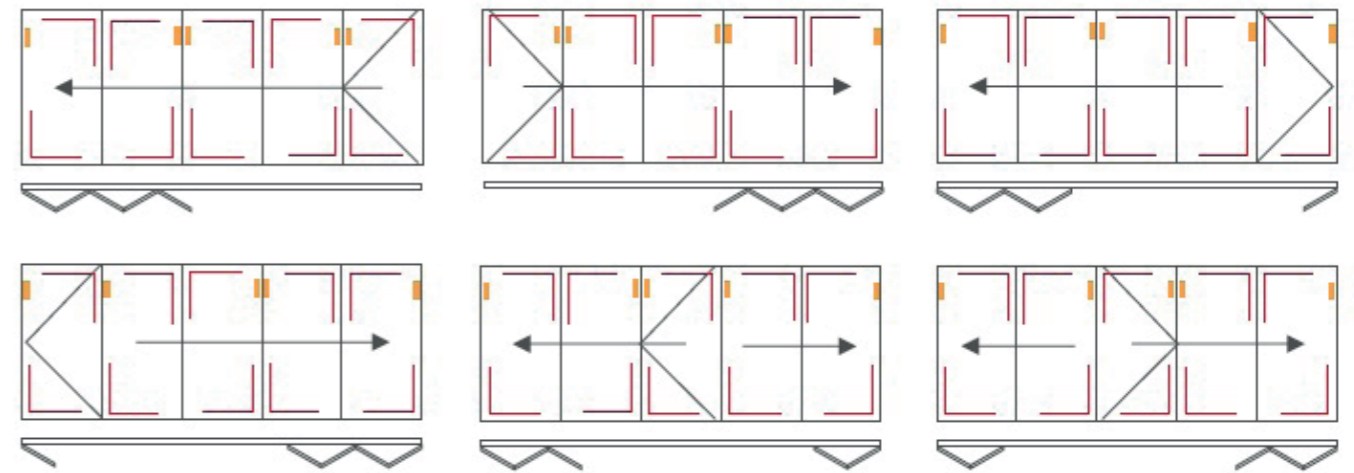

6 PANELS

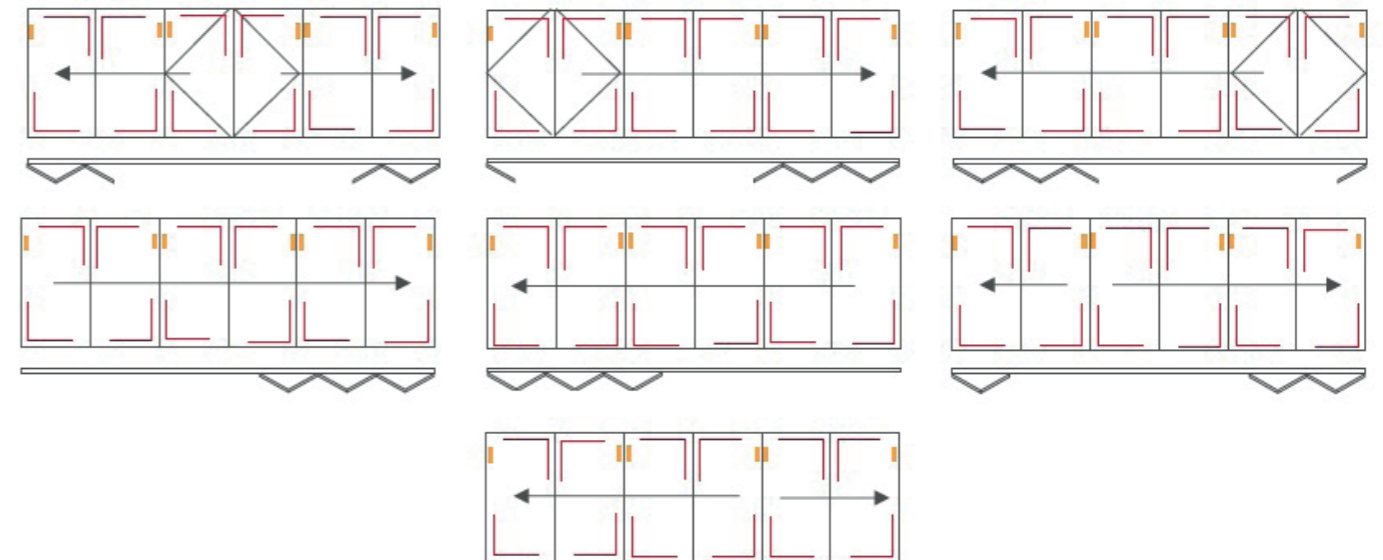



## TRAFFIC DOOR MAGNET RETAINER

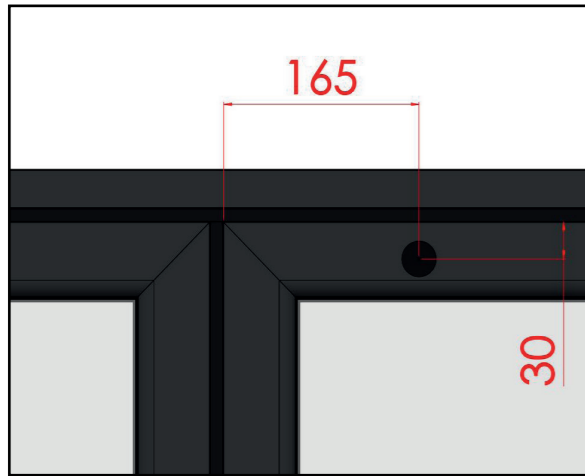

**Traffic door retainer magnets can be supplied to prevent a traffic door handle colliding with the adjacent panel when fully opened.**

To install measure 165mm in and 30mm down from the top handle side corner of the traffic door.



Position magnet over marked position and screw through the hole into the frame through the centre of the magnet using **(screw size)** provided. Once secure slide cover over top of magnet.



Repeat steps 1 and 2 for the adjacent door sash on the side furthest from the hinge of the adjoining traffic door

## DOOR RESTRICTOR (ACDV290)

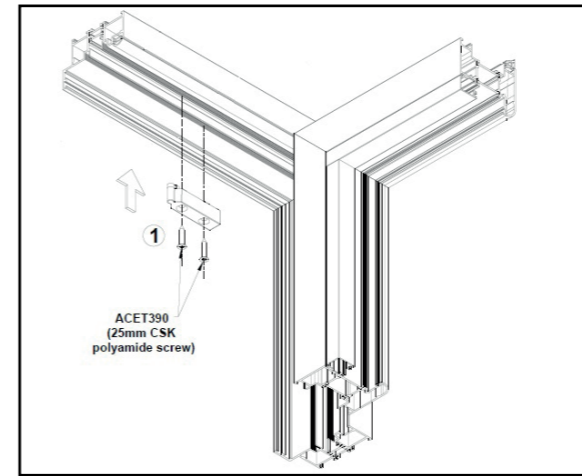

Please note: Even number door configurations with single or double swing applications. (I.e. 3-1) require ACDV290 restrictors fitting. Insert plastic stop into cavity as shown and fix in place using 2 x ACET390 polyamide screws provided.

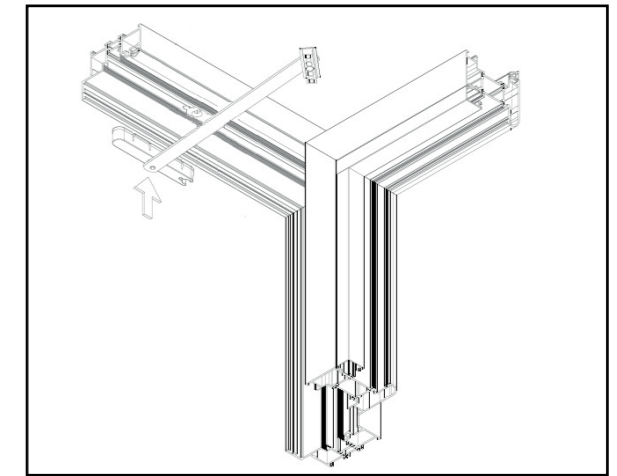

Clip the grabber catch into the same cavity as shown. Ensuring the component moves freely within the channel. If required apply Teflon lubrication spray.

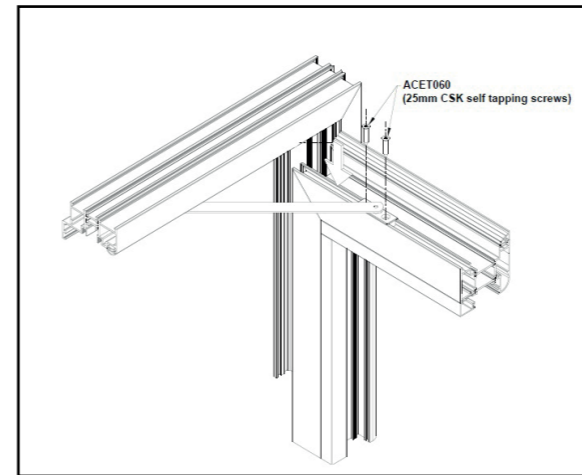

Finally, position door leaf at 90° and insert restrictor bracket into the internal gasket channel on the sash as shown. Spot and drill 2 x Ø3mm holes then fix bracket in place using 2 x ACET060 self-tapping screws.



# OPAL

ALUMINIUM WINDOWS AND DOORS

**OPAL DEFINITIVE & DELUXE**

INSTALLATION GUIDE