



Prefix **WARM**roof®

- PRODUCT GUIDE -



WARMROOF BY NAME & DESIGN

The WARMroof system from Prefix Systems is the most configurable and structurally robust solid, insulated and tiled roof in the UK market, as our exhaustive testing and research has shown. It's the first off-site constructed 'warm roof' of its kind that has been designed and engineered in house and has been installed on thousands of homes across the UK. The Prefix WARMroof® is the most innovative, desirable, aesthetically pleasing and advanced roof system available for home extensions and conservatory refurbishment projects.

It's not just on the outside that our WARMroof system excels, but it's in the product engineering inside that really sets us apart in this important and emerging market sector.

Other insulated and tiled roof systems have not been designed using the modern and accepted best method of 'warm roof' construction. Others have chosen the use of 'cold roof' construction, which our research has shown can result in the risk of condensation & over time, decay. UK Building Control departments will always advise a warm roof construction over a cold roof alternative, as a warm roof is more suited to the UK climate.

Structural integrity, warm roof construction, design configurability and ease of installation are the four corner stones of the Prefix WARMroof® system. The system is available with on-site assistance and marketing & sales support from our four branches, which serve the entire UK.

Prefix **WARMroof**®

STRUCTURE

TILES

Envirotiles, Britmet or TapcoSlate from stock or real slate, clay or concrete tiles of your choice in a variety of colours

MEMBRANE

Breathable, waterproof membrane between the top panels and tiles to assist with weatherproofing

INTERNAL PANELS

Built in timber battening for secure fixing plasterboard

HIP & RIDGE CAPPINGS

Slimline one-piece top cap cover for speed of installation which matches roof slate or tiles

WARMROOF LAYER

Extra 70mm top panel phenolic insulation which insulates the bars and eliminates potential thermal bridging issues to create a true 'warm roof' structure and provides 0.15 'U value' to comply with UK building regulations

RAFTER INSULATION

100mm insulation between the bars, retaining the heat within the room. Incorporates timbers to accept plasterboard fixings. Provides 170mm of insulation overall bonded to the structural 15mm plywood deck

GUTTER & FASCIA

Available in a variety of colours and soffit depths & with optional NEW aluminium gutter shroud for superior aesthetics

EAVES

Fully insulated eaves, eliminating any risk of condensation. Variety of soffit depths available

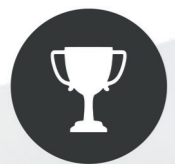

AWARD WINNING



QUICKEST



WARMEST

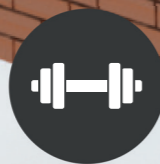

STRONGEST



EASIEST

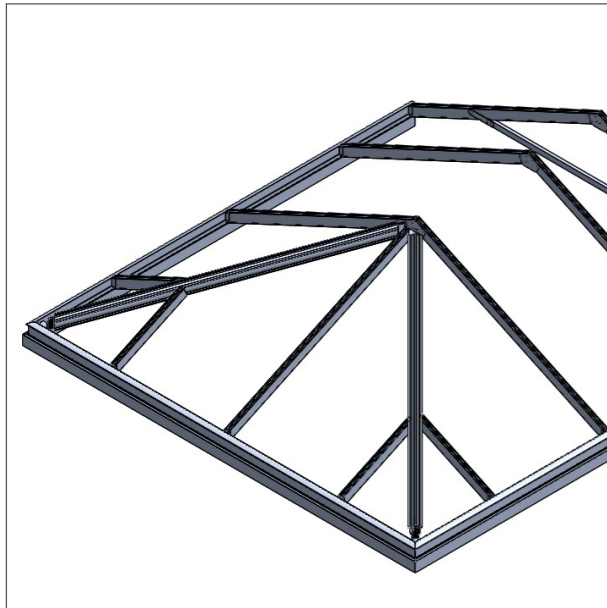

STRUCTURAL A FRAMES

- Fixed 'A Frame' rafter not only adds structural strength but prevents movement, which unlike timber, helps eliminate the risk of finished plaster cracking.
- No ridge section (as seen on traditional roof design) adds to configurability of the system and speed of installation.
- Proven to the latest Eurocodes - it's structurally proven in all UK postcodes areas.
- Structurally tested to take the weight of lightweight tiles or traditional clay or slate tiles.
- Capable of spans of over 6 metres wide.

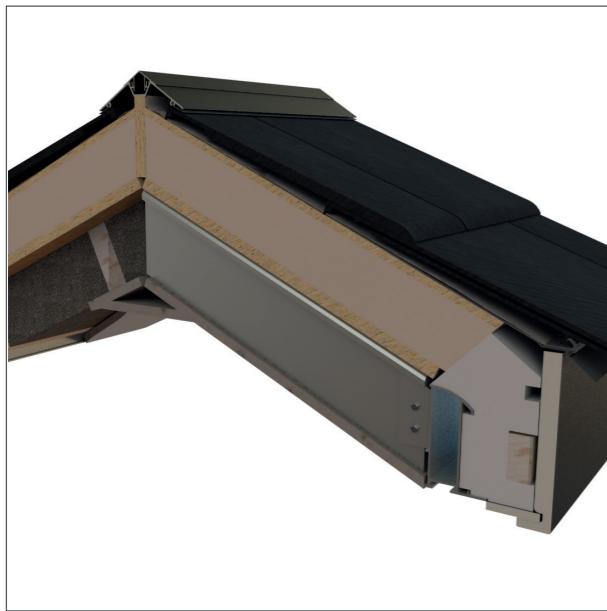

'WARM ROOF' CONSTRUCTION

- The only warm roof construction of its type.
- The only system to be insulated at the eaves to prevent condensation.
- Preformed insulated panels for ease of installation and handling making for a better, faster installation process.
- Insulation forms part of the panel and the top layer sits above the aluminium structure forming a true 'warm roof' deck.
- One piece hip and ridge cappings makes for quick installation, with built in gaskets for better weather performance.

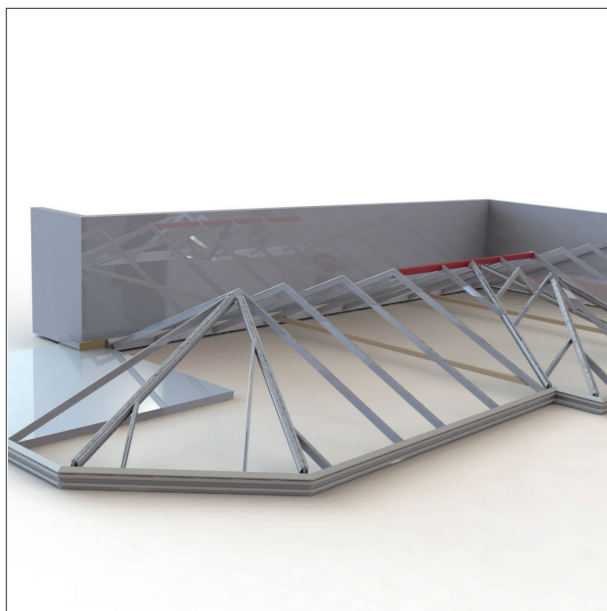

CONFIGURABLE DESIGNS

- Almost **any** roof design, pitch or angles can be achieved.
- Perfect for new build, re-roofing & conservatory replacement projects.
- No ridge section means almost any design is possible.
- Variable soffit and fascia overhang detail, making for a traditional roof appearance.
- Almost unlimited design capability unlike timber and SIP designed roofs.



ROOFLIGHTS & GLASS

- Velux rooflights are pre-fitted into the panel to speed up installation on site and can be glazed into hipped ends.
- Fixed Hybrid glass units to maximise light into the room.
- Our Hybrid & Velux options allow for a choice of large fixed glass units or opening for added ventilation.
- Velux sizes available up to a maximum of 1800mm long.

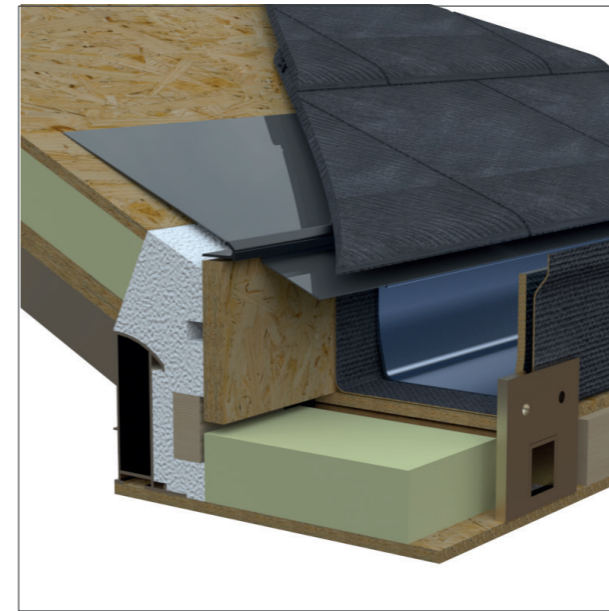

BOX GUTTER ASSEMBLY

- The only roof to offer a range of structural solutions for our insulated box gutters including hidden interlocking wall brackets as standard, which sit between 50mm PIR insulation and 9mm OSB to prevent thermal bridging.
- No unsightly gallows brackets if additional supports are required.
- House soffit detail with optional adjustable rafter fixing brackets for extra structural peace of mind.

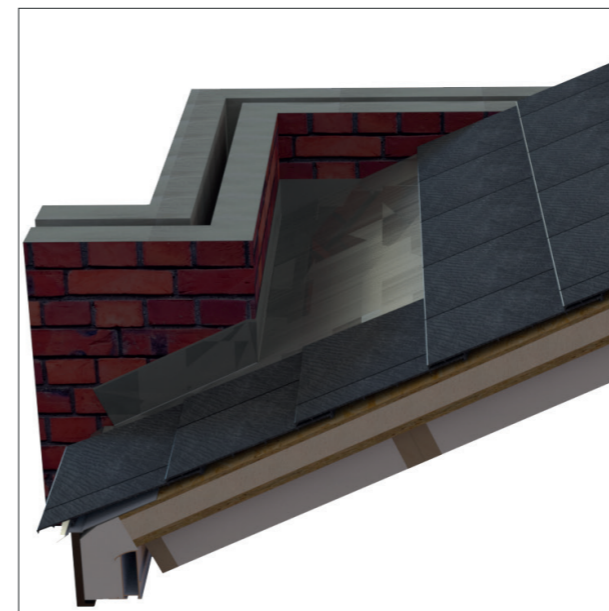

FLASHING TRAY

- Bespoke aluminium flashing tray offers a hassle free alternative to raised back box gutters against the house wall.
- The flashing trays are quick and simple to install and sit directly onto the external membrane up under the tiles and have a raised upstand to make the lead flashing easier - a simple yet very effective water-tight solution.
- Effective, neat and cost effective solution.

TECHNICAL INFO

KEY DIFFERENCES

VS. CHEAPER ALTERNATIVES

Size considerations

- Strongest solid roof system on the market.
- Spans of over 6m and beyond on certain styles & designs*.
- No tie strut required up to 6m wide.
- Steel inserts in eaves for spanning bi-folding door openings.
- Steel beams are used for larger door openings

Shape and style considerations

The Prefix WARMroof® system is designed to accommodate all pitched roof designs, including existing conservatory roof styles as these are more complex than normal extension type roofs. Therefore, to date, we haven't had a roof design that is beyond the scope of the roof's capabilities.

The Prefix WARMroof® is a 'one roof' fits all solution for any style of home extension.

Pitch considerations

- 14° Minimum Pitch on Lean-to Roofs with Tapco Slate.
- 10° Minimum Pitch on Roofs with Velux Windows.
- 12.5° Minimum Pitch on Lean-to Roofs with Envirotile
- 5° Minimum Pitch on Contemporary Roof, Lean-to only (Steel Cladding) or EPDM membrane

Guarantees

Subject to our normal terms and conditions the Prefix WARMroof® roof is fully guaranteed for 10 years. The tiles carry their own warranty with Tapco and Britmet offering a 40 year warranty & Envirotile offering a 25 year warranty.

Weight Restrictions

- Roof Weight per m² = 53kg (Envirotile)

- The Prefix WARMroof® system offers 170mm of insulation in total, more than most other similar type roof systems, making for a far better performing 'warm roof' solution.
- Our 70mm continuous external thermal barrier creates a true 'warm roof' eliminating any risk of condensation (warm deck).
- The insulated eaves stops cold bridging that causes condensation inside against the plasterboard - competitors roofs don't have one and are therefore liable to condensate!
- Thermal insulation U-value of 0.15 W/m²K as standard.
- Proven roof span over 6m wide, even with concrete or clay roof tiles - option to dress roof with traditional slate or roof tiles to match existing house roof. Wider spans can be achieved on certain designs/shapes.
- Structural integrity as standard, with 'fixed joint' technology. Competitor roofs are similar in construction to a conservatory roof and therefore are flexible as they have 'pinned joints.' This is an important point to consider when fitting plasterboard roof designs to prevent movement or cracks appearing. Always ask about fixed joints.
- Roof structurally proven to the latest Eurocodes - many of the competitor roofs are not and makes theirs very limited structurally. Often they have only made structural calculations available for a small portion of the UK, i.e. up to 100m in altitude with less snow fall or lower wind speeds.
- Pre-formed insulated panels reduces install time - with many of the competitor roof systems, the insulation and board needs cutting to size and fixing on site. Errors will occur, quality of construction can be poor, specification can change and the build process will be longer, difficult and untidy.
- We can offer an optional fascia and soffit detail for a traditional roof feel - most of the competition roofs don't have one and they can often look unfinished. You can add lighting into a larger soffit.
- BBA Approved 'dry fit' tile system as standard. Competitor roofs have a steel tile with a thin layer of powdered stone glued on top, an industrial looking finish in our view and requires considerable battening underneath.
- With competitor roof systems, the steel tiles and roof system is only guaranteed when a batten is used, but most companies don't fit them according to our research - the battens aid ventilation required for 'cold roof construction'. These battens slow the build time down and are therefore ignored, which results in a poorer performing roof which will rot & decay resulting in guarantee issues.
- 10° to 45° pitch range as standard. But down to 5° with the contemporary steel roof or EPDM membrane solution, with other additional pitches available on request. No other solid, insulated tiled roof system can achieve this.
- We can offer a facet overhang option - there are a lot of 3 bay Victorian conservatory stock in the UK. We can install a Georgian (two front hips) roof onto three bay Victorian frames, as our roof is structurally superior allowing us to do this. It's also perfect for downlighters. See page 12.
- We only use **Velux** roof lights and they are pre-fitted into panels - this speeds up installation time. The competitor roofs only offer a cheaper alternative. Prefix only specify the highest quality materials & components within our Prefix WARMroof® system. This guarantees longevity and aesthetics will not deteriorate over time.

*4m on gable designs

WARM VS COLD

Our WARMroof system, is the only true 'warm roof' construction in the solid, insulated and tiled roofing sector. The insulation sits above the roof structure keeping the whole structure warm and no chance of thermal bridging or condensation forming.

A 'warm roof' construction has many benefits over a traditional 'cold roof' and is essentially a 'breathable roof construction', allowing moisture to escape, which in turn prevents damp and any associated decay problems. It is thermally efficient, cost effective and is commonly accepted as the **best** roof construction option for our climate within the UK. A 'warm roof' construction also increases the effectiveness of the insulation and prevents warm air leakage from the building into the roof space. The Prefix WARMroof® will not suffer condensation due to its warm roof construction and is the only roof of its type to offer this modern method of construction. A typical competitor system, clearly shows the cold spots under the glazing bars, with the corresponding issue of condensation to the inside plasterboard.

It is the most thermally efficient system of its kind on the market today.

WARM ROOF CONSTRUCTION

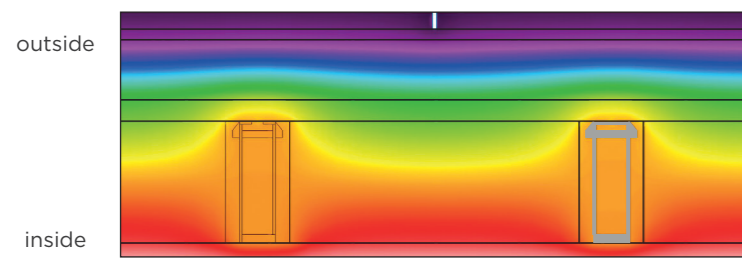

As you can see from the enhanced thermal simulations opposite, a Prefix WARMroof® will not suffer condensation due to its 'warm roof' construction and is the only roof of its type to offer this modern method of construction. The lower image showing a typical competitor system, clearly shows the cold spots under the glazing bars, with the corresponding issue of condensation to the inside plasterboard.

COLD ROOF CONSTRUCTION

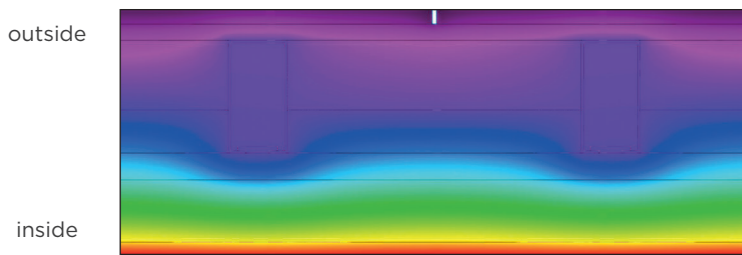

As a result battening and counter battening is always required with a 'cold roof' construction, something not required with our Prefix WARMroof® system.

With an average room temperature of 20°C and a UK average of 50% humidity to the inside of a property, the dew point is 9°C and so condensation can affect solid, insulated tiled roofs with a cold roof construction for over half of the year.

By specifying a Prefix WARMroof® from the outset, there will be no call backs or remedials as a result of mould or condensation to the inside plasterboard.

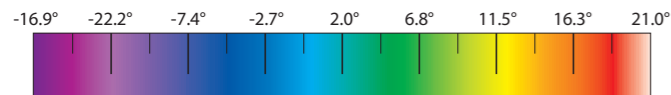

Prefix WARMroof Warm Roof Section Cut Through

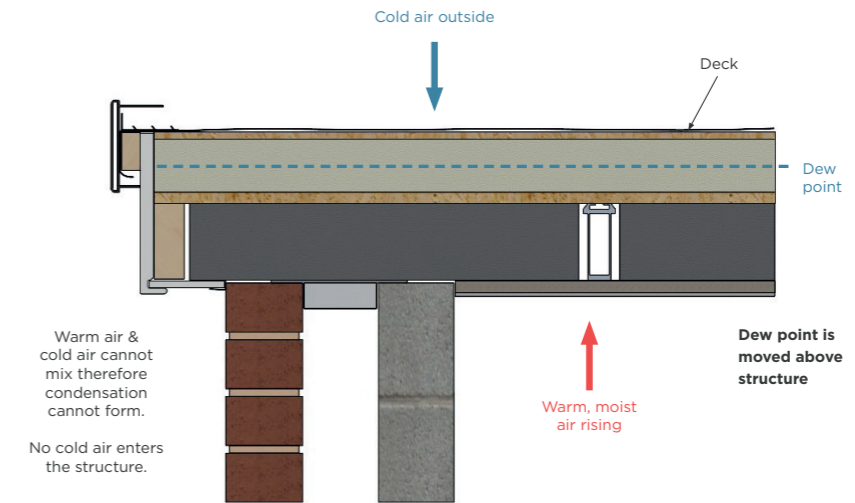

- The Prefix WARMroof® is a 'warm roof' construction that eliminates the risk of interstitial condensation
- The insulation is placed outside the roof structure in a WARMroof, between the rafters to keep the entire structure warm
- A warm roof construction prevents mixture of cold and warm air streams and moved the dew point above the structure of the roof. This means condensation cannot form within the roof structure and eliminates any risk of rot or decay as a result.
- The Prefix WARMroof® requires no additional ventilation under the tiles and/or roof deck
- The Prefix WARMroof® is a 'fit and forget' product that eliminates the risk of condensation, mould growth or rot

Typical Competitor Roof - Cold Roof Section Cut Through

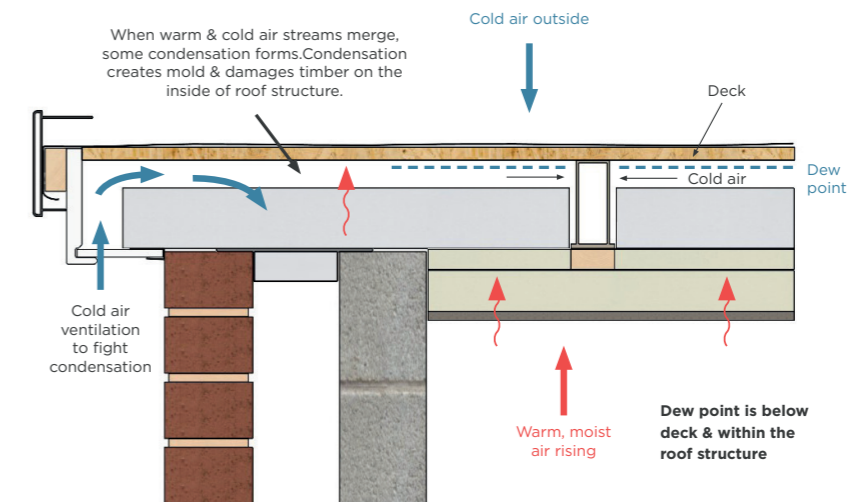

- Condensation occurs when water vapor in the air condenses from a gas into a liquid, and it can happen on any cold surface
- Interstitial condensation occurs when moist air vapor penetrates through the elements of a building's fabric and condenses within the building fabric itself
- Cold roofs, require ventilation to prevent interstitial condensation
- Interstitial condensation is unseen and can cause damage to the structure from the inside if not dealt with swiftly and properly

DESIGN OPTIONS

1 - INTERNAL PELMET

We can create an internal pelmet detail, which is pre-cut to size so lighting or speakers can be installed around the internal perimeter and not in the slope of the roof. It also offers an alternative design feature.



2 - VELUX WINDOWS

We only use brands we trust! Velux are the world leaders in roof-lights and for good reason; they are the best technically, offer a wide range of options and are widely trusted by consumers. These are pre-fitted into the panels in our factory to speed up installation on site and can also be glazed into hipped ends. They are available as electric, manual and with or without blinds.



3 - CORNER OVERHANGS

There are a lot of 3 bay Victorian conservatories already installed in the UK. We can install a Georgian (two front hips) roof onto three bay Victorian frames, as the Prefix WARMroof® is structurally designed and tested to allow the roof to cantilever the eaves section over the facets. This feature also offers the facility for a down-lighter to each corner, allowing homeowners to add additional lighting making for a brighter environment.



4 - GUTTER SHROUD - NEW!

All aluminium gutter shroud which is simple to install yet provides a stylish and superior finish. The gutter shroud masks the PVC gutter sat behind it, guaranteeing the powder coated finish will not discolour or fade over time. An ingenious support bracket has been designed to support the shroud from within without any unsightly wires or hanging brackets. The shroud has been designed to provide stunning architectural detailing.



5 - SOFFIT OPTIONS

The Prefix WARMroof® has three soffit depth options; a zero soffit for installing onto window frames or where tight boundaries are an issue, a 50mm depth for a more traditional feel which works with full height brickwork or a 100mm soffit for integration or downlights where more depth is usually required.



WHY PREFIX WARMROOF®?

- **WINNER** of Best Solid Roof
- True warm roof construction
- Most configurable roof system on the market
- Aluminium structure fully insulated
- Additional battening out not required, internal timber battens built into the base panels
- Strongest system on the market, capable of spans over 6000m wide
- Insulated eaves, variable soffit depths
- Maximum 1200mm bar centres
- Ventilation gap not necessary
- Frame add-on not required
- Heavy duty traditional clay, concrete or slate tiles can be used
- Velux pre-fitted, manual or electric opening options
- Triple glazed Hybrid option available, maximising glazed areas
- One piece hip & ridge covers for speedy installation
- No need for on-site cutting of materials
- Gutter shroud option for enhanced aesthetics
- Quickest industry installation times
- Site deliveries & palletised roof deliveries
- Lowest 'U' values on any roof system available
- On site assistance & technical support from 4 sites across the UK
- 3 tile options from stock in a variety of colours
- Building regulations compliant for the whole of UK Design software available for design, pricing and 'E' ordering



VOTED BEST SOLID ROOF!

The Prefix WARMroof® was voted **BEST Solid Roof System** at the Conservatory & Orangerie awards with judges commenting:

"An extremely well designed and robust system, with impressive pitch ranges and options for triple glazing"



TILE OPTIONS

When it comes to the external appearance of the Prefix WARMroof®, we offer 3 stock tiles to choose from in a range of colours. The Prefix WARMroof® also offers the choice to bespoke the external finish as structurally proven to take concrete, clay and slate tiles to match the existing house roof.

ENVIROTILE

A flat, precision manufactured, recycled polymer, lightweight roof tile with excellent green credentials. This lightweight roof tile is extremely simple to fix yet performs exceptionally, locking into adjacent tiles to form a fully integrated roof covering. It is easy to cut and work with and is robust enough for fitters to walk on it during the installation process and there is no need for additional battens when installed onto our warm roof deck.

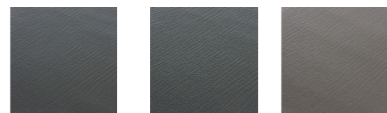

Anthracite Black Slate Grey Dark Brown

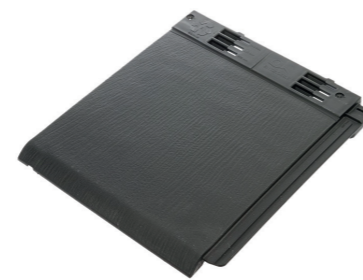

BRITMET

Britmet's Liteslate is a cost effective yet innovative synthetic slate roofing tile made from 90% recycled polymers with all the characteristics you can expect from a traditional slate tile. Liteslate offers an authentic finish with riven edges, traditional colour choices and impeccable durability. Unlike natural slate, as a synthetic slate roofing tile, Liteslate won't crack, break, chip or delaminate due to its ground-breaking design and cutting-edge manufacturing process. Over 90% of the Polymers that Liteslate is made from are recycled.



Charcoal Ash Slate Grey Amethyst Oak Sunshine Sunset



TAPCOSLATE

TapcoSlate tiles are the premium slate effect product, authentically shaped with textured surfaces and riven edges moulded from authentic slates that make them indistinguishable from natural slate. It is made from a recyclable blend of limestone and polypropylene. TapcoSlate tiles will not crack, break or delaminate, and its product formulation and manufacturing processes provide durability, performance, and longevity for many years. The TapcoSlate tiles come with a 40 year warranty.



Stone Black Pewter Grey Plum Chestnut Brown Brick Red



	Envirotile	Britmet Liteslate	TapcoSlate
Width	325mm	297mm	295mm
Height	365mm	445mm	445mm
Weight	610g	600g	650g
Thickness	11mm	5mm	5mm
Minimum pitch	12.5°	12°	12°
Maximum pitch	90°	90°	90°
Warranty	25 years	40 years	40 years

Ask! To see samples of our tiles / colour swatches

WARMROOF HYBRID

The Prefix WARMroof® Hybrid option allows even more light to flood into any extended living space. The fixed glazed panel allows you to retain an element of light within the room yet keep the thermal efficiency due to the 28mm double (or 44mm tripled glazed units that provide a 0.6 U-Value).

The WARMroof Hybrid system has a plastered finish internally which provides a simplistic and contemporary finish where the glass panels are positioned. The plaster detail also allows the homeowner to personalise the finish by painting up to the glass to match interiors. The option for painting will also match in with our standard Velux rooflight which is offered in a white painted finish, meaning you can mix and match fixed and opening rooflights for added ventilation. Thermal properties are not compromised using our hybrid option, resulting in clean lines and unrivalled thermal performance whilst always maximising the light into your new living space.

- Roof pitches from 12.5° - 35°
- Configurable roof pitches – different elevation pitches
- Unrestricted projection for gables, victorian, georgian etc (subject to adequate side wall design)
- Flexible soffit sizes
- 28mm double glazing as standard with the option to upgrade to 44mm triple glazing
- It's the only triple glazed full ridge to eaves glass roof light incorporated into a warm roof
- A U-Value of 0.6 compared to the best double glazed option of 1.2 in other systems
- By creating a bespoke PVC thermal break we allowed sleek, contemporary exterior lines, keeping the glass in line with the tiles
- The plasterboard finish to allow homeowners to paint up to the glass
- Fast installation alongside the rest of the Prefix WARMroof® system
- The way the Hybrid works with the existing roof framework also allows numerous configurations allowing back to back glass panels, single sided glass panels, rows of 2+ glass panels next to each other, with up to 1m wide panels of uninterrupted light transmittance with no effect on the structural performance of the roof
- Lighting options available – APEX, pelmet, soffit areas
- Glass filmed top & bottom for clean, sleek glass units whilst hiding cavity walls being seen

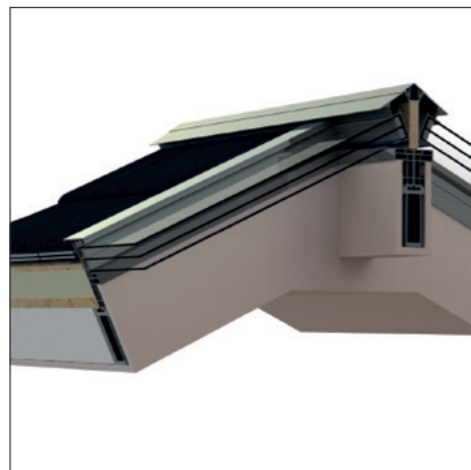
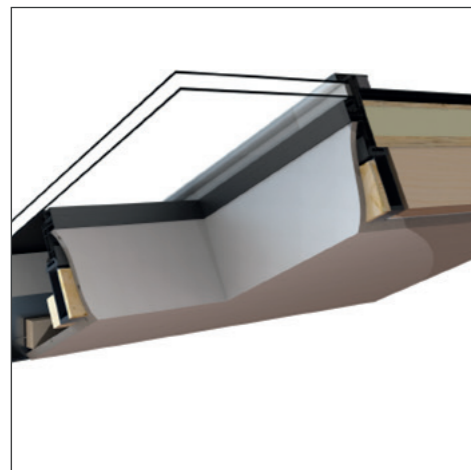



BUILDING REGULATIONS

If you are planning to re-roof an existing conservatory with a solid roof rather than a translucent roof, then a Building Regulation Application is typically required, although we recommend you seek the advice from your local authority. Prefix WARMroof® conforms to the very latest building control regulations issue June 2023 for use on both new builds and home extensions.

Type approval of the Prefix WARMroof® means that the process of obtaining a building control certificate for your project is very straightforward. In having the certification from JHAI, the pre-approval of the system means that the delays associated with applying building control certification are eliminated. The pre-approval system is designed to fast track the approval process, speeding up the whole installation of the Prefix WARMroof® and saving the consumer money in the process.

As with all replacement roof only projects, we recommend that our good practice guide is followed before works commence. Any queries can be discussed directly with our technical team or with JHAI directly. Visit our website to download the **'Good Practice Guide.'**

We've partnered up with **JHAI Ltd** who are one of the UK's largest and most trusted approved inspector companies, licensed every five years by the government - via the Construction Industry Council (CIC). They carry out building regulations approvals (Building Control) as an alternative to Local Authorities.

The view of Local Authorities and Building Control inspectors can and does vary between boroughs, as the criteria for Building Control is not clearly documented when it comes to conservatory type roofs and the replacement of. Therefore, Prefix Systems® have sought to simplify the process by providing a single point of contact nationwide through JHAI. The homeowner will still be issued with a valid completion certificate.

JHAI have fully assessed our Prefix WARMroof® system in terms of its design, application and structural capabilities. Through JHAI there are also random site inspections estimated at around 1 in 20 and in many instances this will be carried out remotely. The cost for a replacement conservatory project is approx. £250 and for a new installation, approx. £450. The application form can be sent upon request or you can make an application on their website.



- ▶ Fill out the application form and send to JHAI direct who will contact you to process your project. Alternatively, send to Prefix and we can forward your application to JHAI.
- ▶ Take a photo before any works start. It is an important part of the process that at least one photo is taken **BEFORE** any work commences.
- ▶ Take some more photos internally and externally during the building process showing the insulation in place.
- ▶ Take a photo after all works are completed. It is important at least one photograph of the completed works is taken.
- ▶ Prefix WARMroof® installation is completed and a final certificate issued. After the first installation a sample of installations will be inspected by JHAI.

EAVES HEIGHT CALCULATOR

ROOF CALCULATOR

Overall Roof Height Chart - Underside of eaves to top ridge capping

PITCH	WIDTH			APEX STYLE	
	3000	3000	4000	5000	6000
15	659	726	793	927	1061
20	808	899	990	1172	1354
25	968	1085	1201	1434	1667
30	1143	1288	1432	1721	2009
35	1339	1514	1689	2039	2389
40	1561	1771	1981	2401	2820

A-Frame Height Chart - Underside of eaves to top of A-Frame

PITCH	WIDTH			APEX STYLE	
	3000	3500	4000	4500	5000
15	520	587	654	721	788
20	666	757	848	939	1030
25	823	939	1056	1173	1289
30	993	1138	1282	1426	1570
35	1189	1357	1533	1708	1883
40	1397	1607	1817	2027	2237

Overall Roof Height Chart - Underside of eaves to top of tile

PITCH	WIDTH			MONO STYLE	
	2000	2500	3000	3500	4000
10	597	685	773	862	950
15	785	919	1053	1187	1321
20	983	1165	1347	1529	1711
25	1195	1428	1661	1894	2127
30	1410	1717	2005	2294	2583
35	1686	2037	2387	2737	3087
40	1981	2401	2820	3240	3660

Overall Plate Height Chart - Underside of eaves to underside of wall plate

PITCH	WIDTH			MONO STYLE	
	2000	2500	3000	3500	4000
10	365	453	540	628	716
15	547	681	814	949	1083
20	739	921	1102	1285	1467
25	945	1180	1411	1644	1878
30	1168	1457	1745	2034	2323
35	1416	1766	2116	2466	2816
40	1697	2117	2536	2956	3376

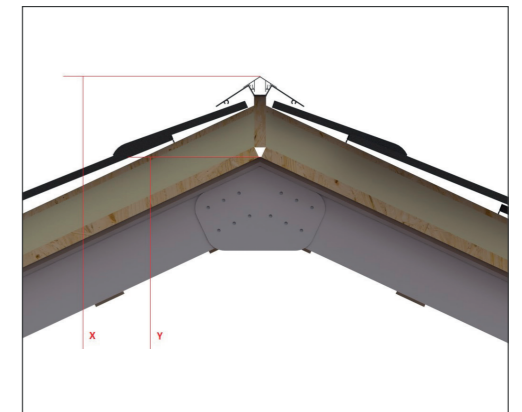

Apex Style

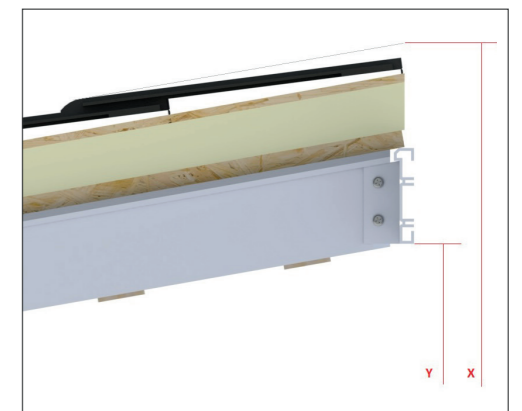

Mono Pitch

0mm SOFFIT				
Pitch	A	B	C	D
5	106	257	244	219
10	106	257	247	213
15	106	257	251	207
20	106	257	257	203
25	106	257	265	200
30	106	257	275	197
35	106	257	289	196
40	106	257	306	197

50mm SOFFIT				
Pitch	A	B	C	D
5	136	287	244	219
10	136	287	247	210
15	136	287	251	200
20	136	287	257	193
25	136	287	265	186
30	136	287	275	182
35	136	287	289	177
40	136	287	306	174

100mm SOFFIT				
Pitch	A	B	C	D
5	186	337	244	212
10	186	337	247	199
15	186	337	251	186
20	186	337	257	174
25	186	337	265	162
30	186	337	275	151
35	186	337	289	140
40	186	337	306	130

Dim A = Internal eaves to external fascia (excluding gutter).

Dim B = Internal eaves to external gutter (including jointer/stop end).

Dim C = Underside of eaves beam to top of a typical lightweight tile (34mm including overlap). This excludes any soaker and leadwork.

Dim D = Fascia Height

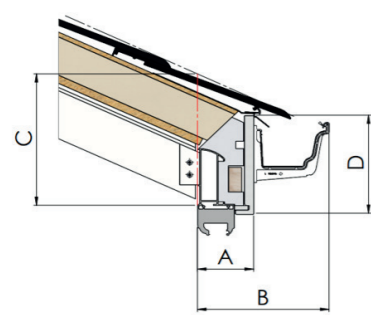

0mm soffit

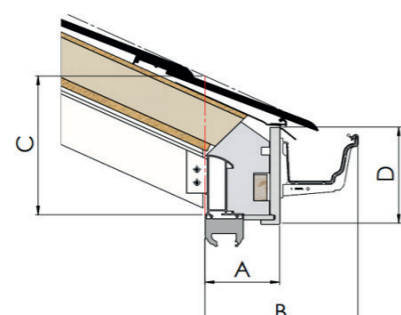

50mm soffit

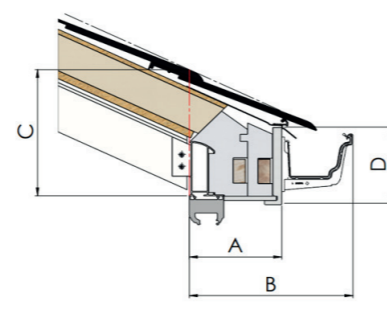

100mm soffit

INSTALLER SCHEME

The Prefix WARMroof® installer scheme is a programme which we'd love for you to be a part of! We are looking for installers across the country to join our team. The Prefix WARMroof® is the BEST Solid Roof on the market and as homeowners look to specify this particular roof, we need talented installers to send these leads to. Our roof is easy to install and a cost effective roofing solution, creating conservatories that people will love!

WHAT'S IN IT FOR YOU?

- ✓ You will be associated with the Prefix Systems® brand with an established market reputation.
- ✓ You will become an **'Official Registered Installer of the Prefix WARMroof®'** giving you credibility with homeowners.
- ✓ You can improve your business margin and turnover, by reducing time on site compared to other systems.
- ✓ We do all the hard work! We invest in the advertising & lead generation then send the information to you to follow up.
- ✓ Our leads are genuine & of good quality resulting in a high conversion rate.
- ✓ We limit our installers in any given area so competition is limited.
- ✓ We have the backing of building control with pre-approval through JHA1.
- ✓ We provide full training and on-site assistance for first installs providing you with confidence in the system.
- ✓ You will receive help and support directly from us from assistance with surveys to sales & marketing support.



If you'd like to become a registered installer for the Prefix WARMroof®, get in touch with our team!
Email us: enquiries@prefixsystems.co.uk or call 01254 871800.

MARKETING SUPPORT

We have a full range of marketing materials to support you with Prefix WARMroof® sales including brochures, take apart samples, tile samples & colour swatches, tips & tricks for installation, installation & technical guides and on site assistance.

We can also supply digital assets including Prefix WARMroof® imagery, PDF brochures and an interactive widget which you can embed into your own website.

For more information about how we can support you with sales or to order marketing materials, please contact our marketing department: marketing@prefixsystems.co.uk



< Brochures



Digital support >

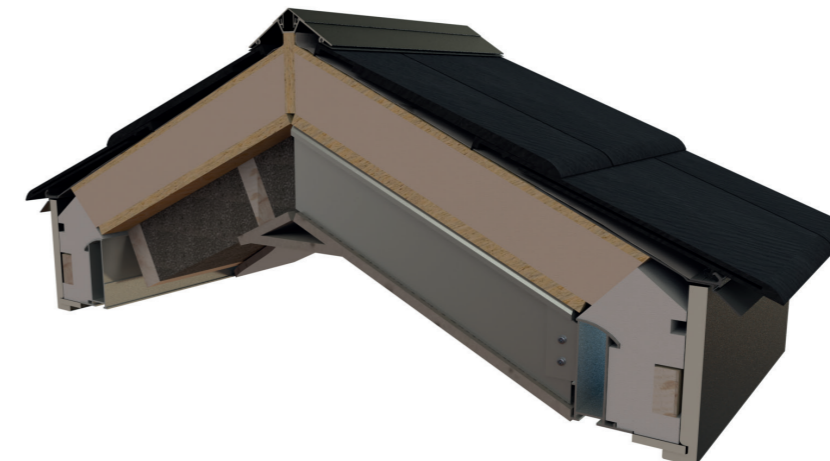

< Samples



Prefix **WARM**roof®

- PRODUCT GUIDE -

